

□ General Description

BYD SiC Power Module BM950F12B34U2 provides low switching, which introduce the advanced SiC MOSFET chip, it is able to take on a perfect performance in various applications with switching frequencies in the range of 1-30KHz.

□ 概述

比亚迪碳化硅功率模块BM950F12B34U2提供低损和高短路能力, 内含先进的碳化硅MOSFET芯片, 在1-30KHZ频率的应用中表现出优良的性能。

□ Key Features

- The 3rd Generation Semiconductor Material-Silicon Carbide
- Blocking Voltage 1200V
- Low $R_{DS(on)}$
- Low Switching Losses
- Low Q_g and C_{res}
- Low Inductive Design $\leq 15nH$
- Ag Sintering
- $T_{vj op} = 175^\circ C$
- Direct Cooled Cu PinFin Base Plate
- High Performance Si_3N_4 Ceramic
- Integrated NTC Temperature Sensor

□ Applications

- Automotive Application
- AC Motor Control
- Motion/Servo Control
- Maximum applied voltage platform: 750V

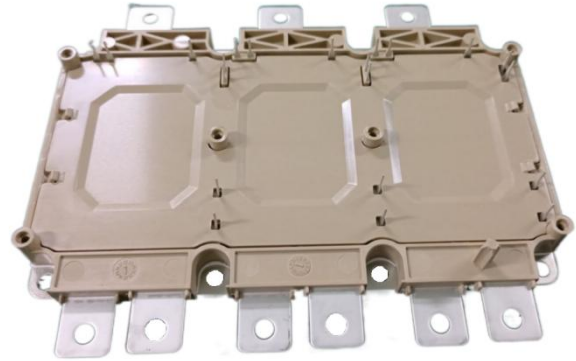

□ 关键特性

- 第三代半导体材料-碳化硅
- 阻断电压 1200V
- 低 $R_{DS(on)}$
- 低开关损耗
- 低 Q_g 和 C_{rss}
- 低电感设计 $\leq 15nH$
- 银烧结工艺
- 最大工作结温 $175^\circ C$
- 直接冷却底板
- 高性能氮化硅陶瓷
- 集成化 NTC 温度传感器

□ 应用

- 汽车级应用
- 电动车/混动车
- 电机驱动
- 最高支持 750V 电压平台



□ Characteristic Values

● Absolute Maximum Ratings/最大额定值

Parameter	Symbol	Conditions	Temperature	Value	Unit
Drain-source Voltage 漏极-源极电压	V_{DSS}	-	$T_{vj}=25^{\circ}C$	1200	V
DC Drain Current 连续漏极直流电流	$I_{D\ nom}$	$V_{GS}=18V$	$T_{vj}=175^{\circ}C,$ $T_F=65^{\circ}C$	550	A
Pulsed Drain Current, t_p Limited By T_{jmax} 脉冲漏极电流	$I_{D\ pulse}$	-	-	1800	A
Maximum transient Gate-source Voltage 栅极电压	V_{GS}	10 hours over lifetime $T_{pulse}<1\ \mu s$	-	-11/+23	V
Gate-source Voltage, Maximum Value 栅极电压	V_{GSmax}	-	-	-5.5/+20	V
Gate-source Voltage 栅极电压	V_{GSop}	-	-	-5/+18	V
Temperature under switching conditions 工作结温	$T_{vj\ op}$	-	-	-40~150	$^{\circ}C$
Total Power Dissipation 耗散功率	P_{tot}	-	$T_F=65^{\circ}C$ $T_{vj}=175^{\circ}C$	1180	W

● MOSFET Characteristics/MOSFET 特性

Parameter	Symbol	Conditions	Temperature	Min.	Typ.	Max.	Unit
Drain-source On Resistance 漏极-源极内阻	$R_{DS(on)}$	$V_{GS}=18V, I_D=420A$	$T_{vj}=25^{\circ}C$	-	1.9	3.2	m Ω
		$V_{GS}=18V, I_D=420A$	$T_{vj}=175^{\circ}C$	-	4.6	-	m Ω
Drain-source Breakdown Voltage 漏极-源极击穿电压	$V_{(BR)DSS}$	$V_{GS}=0V, I_D=1mA$	-	1200	-	-	V
Gate Threshold Voltage 栅极阈值电压	$V_{GS(th)}$	$I_D=70mA, V_{DS}=V_{GS}$	$T_{vj}=25^{\circ}C$	2.1	3.2	5.8	V
		$I_D=70mA, V_{DS}=V_{GS}$	$T_{vj}=175^{\circ}C$	1.6	2.5	4.6	V
Gate to Source Charge 门极对源极电量	Q_{gs}	$V_{DS}=850V,$	-	-	518	-	nC
Gate to Drain Charge 门极对漏极电量	Q_{gd}	$V_{GS}=-5V\ to\ 18V,$	-	-	280	-	nC
Total Gate Charge 门极总电量	Q_g	$I_D=900A$	-	-	1330	-	nC
Internal gate resistor 内部栅极电阻	R_{Gint}	$f=1MHz$ $T_j=25^{\circ}C$	-	-	1.6	-	Ω
Input Capacitance 输入电容	C_{iss}	$V_{DS}=850V, V_{GS}=0V$	-	-	28	-	nF
Output Capacitance 输出电容	C_{oss}		-	-	1.61	-	nF
Reverse Transfer Capacitance 反向传输电容	C_{rss}	$f=1MHz$	-	-	154	-	pF
Gate-source Leakage Current 栅极-源极漏电流	I_{GSS}	$V_{GS}=20V$	$T_{vj}=25^{\circ}C$	-	-	100	nA
Zero Gate Voltage Drain Current 漏极-源极漏电流	I_{DSS}	$V_{DS}=1200V$	$T_{vj}=25^{\circ}C$	-	-	150	μA



Parameter	Symbol	Conditions	Temperature	Min.	Typ.	Max.	Unit
Turn-on Delay Time, Inductive Load 开通延迟时间	$t_{d(on)}$	$V_{DS}=650V$ $I_{DS}=550A,$ $R_{Gon}=12.4\Omega,$ $R_{Goff}=8.25\Omega$ $V_G=-5V/+18V$ $L_S=30nH$	$T_{vj}=25^\circ C$	-	110	-	ns
			$T_{vj}=150^\circ C$	-	67	-	ns
			$T_{vj}=175^\circ C$	-	66	-	ns
Rise Time, inductive load 上升时间	t_r		$T_{vj}=25^\circ C$	-	113	-	ns
			$T_{vj}=150^\circ C$	-	99	-	ns
			$T_{vj}=175^\circ C$	-	98	-	ns
Turn-Off Delay Time, Inductive Load 关断延迟时间	$t_{d(off)}$		$T_{vj}=25^\circ C$	-	536	-	ns
			$T_{vj}=150^\circ C$	-	602	-	ns
			$T_{vj}=175^\circ C$	-	614	-	ns
Fall Time, Inductive Load 下降时间	t_f		$T_{vj}=25^\circ C$	-	71	-	ns
			$T_{vj}=150^\circ C$	-	75	-	ns
			$T_{vj}=175^\circ C$	-	77	-	ns
Energy Dissipation During Turn-on Time 开通损耗	E_{on}	$T_{vj}=25^\circ C$	-	30	-	mJ	
		$T_{vj}=150^\circ C$	-	27	-	mJ	
		$T_{vj}=175^\circ C$	-	28	-	mJ	
Energy Dissipation During Turn-off Time 关断损耗	E_{off}	$T_{vj}=25^\circ C$	-	48	-	mJ	
		$T_{vj}=150^\circ C$	-	48	-	mJ	
		$T_{vj}=175^\circ C$	-	49	-	mJ	
Turn-on Delay Time, Inductive Load 开通延迟时间	$t_{d(on)}$	$V_{DS}=650V$ $I_{DS}=950A,$ $R_{Gon}=12.4\Omega,$ $R_{Goff}=8.25\Omega$ $V_G=-5V/+18V$ $L_S=30nH$	$T_{vj}=25^\circ C$	-	128	-	ns
			$T_{vj}=150^\circ C$	-	82	-	ns
			$T_{vj}=175^\circ C$	-	75	-	ns
Rise Time, inductive load 上升时间	t_r		$T_{vj}=25^\circ C$	-	146	-	ns
			$T_{vj}=150^\circ C$	-	131	-	ns
			$T_{vj}=175^\circ C$	-	130	-	ns
Turn-Off Delay Time, Inductive Load 关断延迟时间	$t_{d(off)}$		$T_{vj}=25^\circ C$	-	514	-	ns
			$T_{vj}=150^\circ C$	-	574	-	ns
			$T_{vj}=175^\circ C$	-	586	-	ns
Fall Time, Inductive Load 下降时间	t_f		$T_{vj}=25^\circ C$	-	91	-	ns
			$T_{vj}=150^\circ C$	-	94	-	ns
			$T_{vj}=175^\circ C$	-	95	-	ns
Energy Dissipation During Turn-on Time 开通损耗	E_{on}	$T_{vj}=25^\circ C$	-	48	-	mJ	
		$T_{vj}=150^\circ C$	-	47	-	mJ	
		$T_{vj}=175^\circ C$	-	48	-	mJ	
Energy Dissipation During Turn-off Time 关断损耗	E_{off}	$T_{vj}=25^\circ C$	-	103	-	mJ	
		$T_{vj}=150^\circ C$	-	103	-	mJ	
		$T_{vj}=175^\circ C$	-	106	-	mJ	



● Body diode/ 体二极管特征值

Parameter	Symbol	Conditions	Temperature	Min.	Typ.	Max.	Unit
Forward Voltage 反向电压	V _{SD}	I _{SD} =950A	T _{vj} =25°C	-	4.6	5.6	V
		I _{SD} =420A	T _{vj} =25°C	1	3.4	5	V
Peak Reverse Recovery Current 反向恢复峰值电流	I _{rrm}	V _{GS} =-5V/18V, I _{SD} =550A, V=650V, di/dt=18000A/us	T _{vj} =175°C	-	217	-	A
Recovered Charge 反向恢复电荷	Q _{rr}			-	7	-	nC
Reverse Recover Time 反向恢复时间	t _{rr}			-	60	-	ns
Reverse Recovery Energy 反向恢复损耗	E _{rr}		T _{vj} =25°C		0.6	-	mJ
			T _{vj} =150°C		1.9	-	mJ
			T _{vj} =175°C		2.5	-	mJ
Peak Reverse Recovery Current 反向恢复峰值电流	I _{rrm}	V _{GS} =-5V/18V, V=650V, I _{SD} =950A, di/dt=19000A/us	T _{vj} =175°C	-	304	-	A
Recovered Charge 反向恢复电荷	Q _{rr}			-	12	-	nC
Reverse Recover Time 反向恢复时间	t _{rr}			-	70	-	ns
Reverse Recovery Energy 反向恢复损耗	E _{rr}		T _{vj} =25°C		1.3	-	mJ
			T _{vj} =150°C		3.9	-	mJ
			T _{vj} =175°C		4.9	-	mJ

● Thermal-Mechanical Specifications 热阻

Parameter	Symbol	Conditions	Min.	Typ.	Max.	Unit
Thermal Resistance Junction To Coolant 结到冷却介质热阻	R _{th(j-f)}	8L/min;50%乙二醇, 50%水	-	0.093	-	K/W

● Module Characteristics/ 模块特性

Parameter	Symbol	Conditions	Min.	Typ.	Max.	Unit	
Dimensions 尺寸	L x W x H	Typical , See Outline Drawing	154.5×126.5×29.5			mm	
Isolation Test Voltage 绝缘耐压	V _{isoL}	t=1min,f=50HZ	3.8			kV	
Clearance Distance In Air 空气间隙	da	According To IEC 60664-1 And EN 50124-1	Term. To Base	4.5	-	-	mm
			Term. To Term	4.5	-	-	mm
Surface Creepage Distance 爬电距离	ds	According To IEC 60664-1and EN 50124-1	Term. To Base	9	-	-	mm
			Term. To Term	9	-	-	mm
Mass 重量	m	-	-	690	-	g	
Pressure Drop In Cooling Circuit 冷却循环中的压差	ΔP	Δv /Δt=12L/min, T=25°C ,Cooling Fluid=50% Water/50% Ethylenglycol	-	7.5	-	kPa	
Maximum Pressure In Cooling Circuit 冷却循环中的最大压力	P	-	-	250	-	kPa	



Parameter	Symbol	Conditions	Min.	Typ.	Max.	Unit
Stray Inductance Module 杂散电感	L _{sce}	-	-	-	15	nH
Mounting Torque For Modul Mounting 模块的安装扭矩	M	Screw M4-baseplate to heatsink Screw EJOT Delta PT WN5451 25x10 PCB to frame	1.8 0.45	2.0 0.5	2.5 0.55	N·m
Terminal Connection Torque 端子连接扭矩	M	Screw M5-terminal to terminal	3.6	4.0	4.4	N·m

● **NTC-Thermistor Characteristic Values/ 热敏电阻特性**

Parameter	Symbol	Conditions	Min.	Typ.	Max.	Unit
Rated Resistance 额定阻值	R ₂₅	T _C =25°C	-	5.0	-	kΩ
Deviation Of R100 R100 偏差	ΔR/R	TC=100°C, R100=493Ω	-5	-	5	%
Power Dissipation 耗散功率	P ₂₅	TC=25°C	-	-	20.0	mW
B-value B-值	B _{25/50}	$R_2=R_{25}\exp[B_{25/50}(1/T_2-1/(298.15K))]$	-	3375	-	K
B-value B-值	B _{25/80}	$R_2=R_{25}\exp[B_{25/80}(1/T_2-1/(298.15K))]$	-	3411	-	K
B-value B-值	B _{25/100}	$R_2=R_{25}\exp[B_{25/100}(1/T_2-1/(298.15K))]$	-	3433	-	K

Characteristics Diagrams/特性曲线

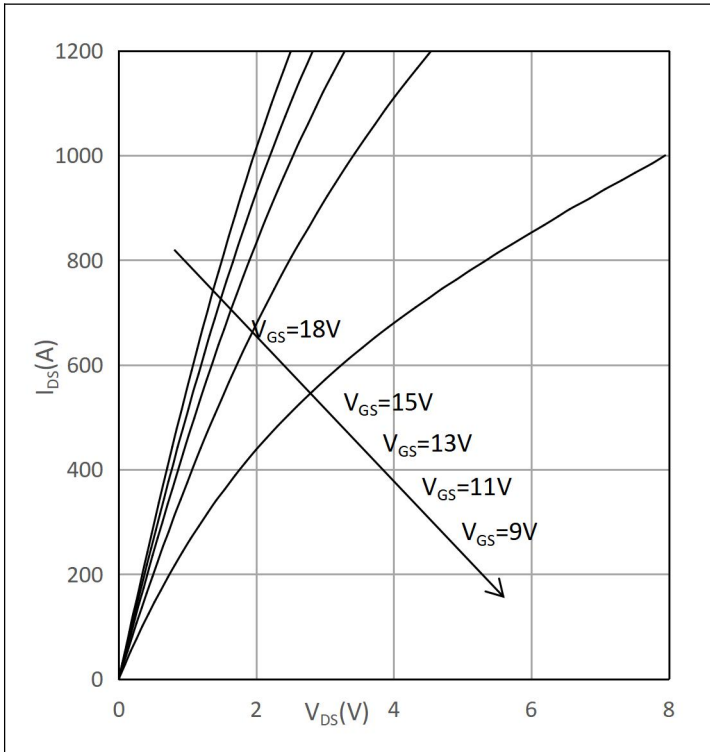

Fig.1 Output Characteristic MOSFET (typical)($T_{vj}=25^{\circ}\text{C}$)
图1: MOSFET输出特性($T_{vj}=25^{\circ}\text{C}$)

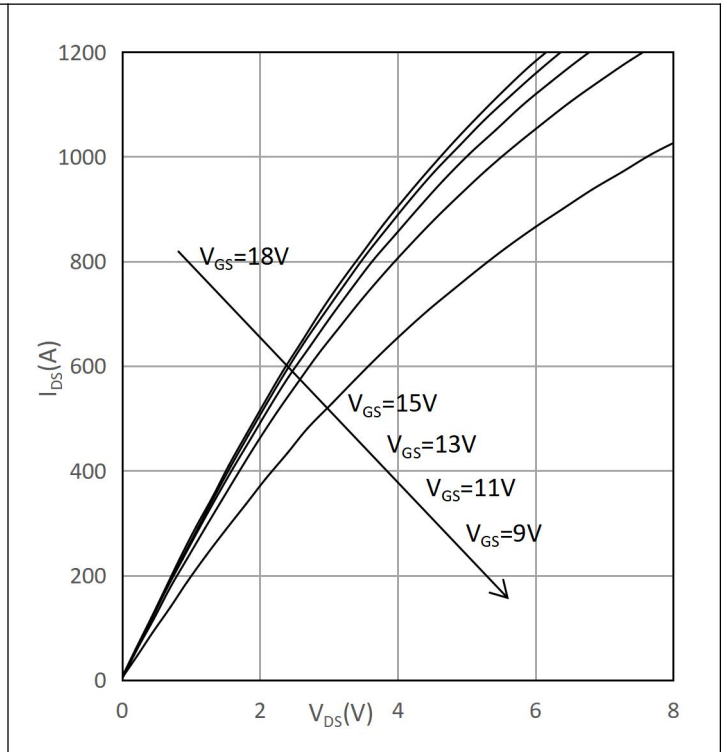

Fig.2 Output Characteristic MOSFET (typical)($T_{vj}=150^{\circ}\text{C}$)
图2: MOSFET输出特性($T_{vj}=150^{\circ}\text{C}$)

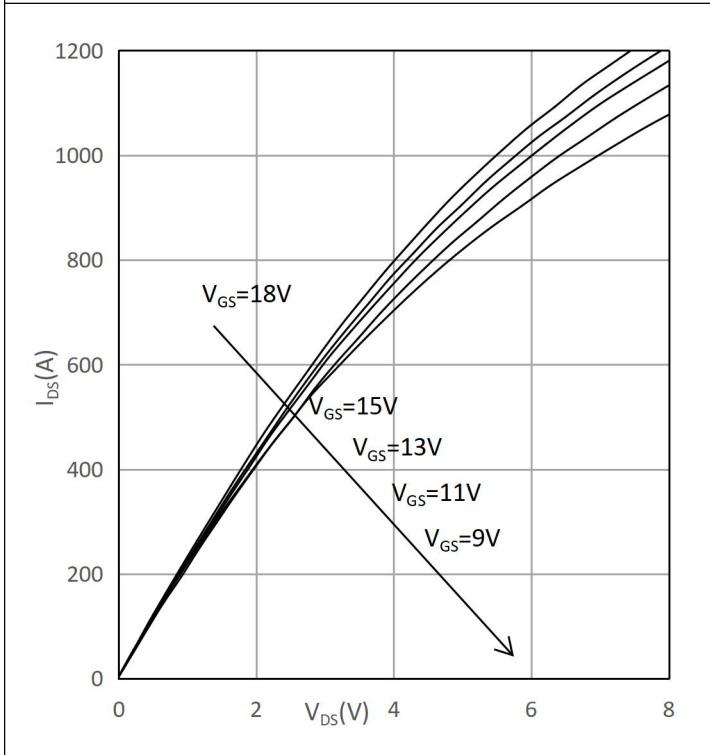

Fig.3 Output Characteristic MOSFET (typical)($T_{vj}=175^{\circ}\text{C}$)
图3: MOSFET输出特性($T_{vj}=175^{\circ}\text{C}$)

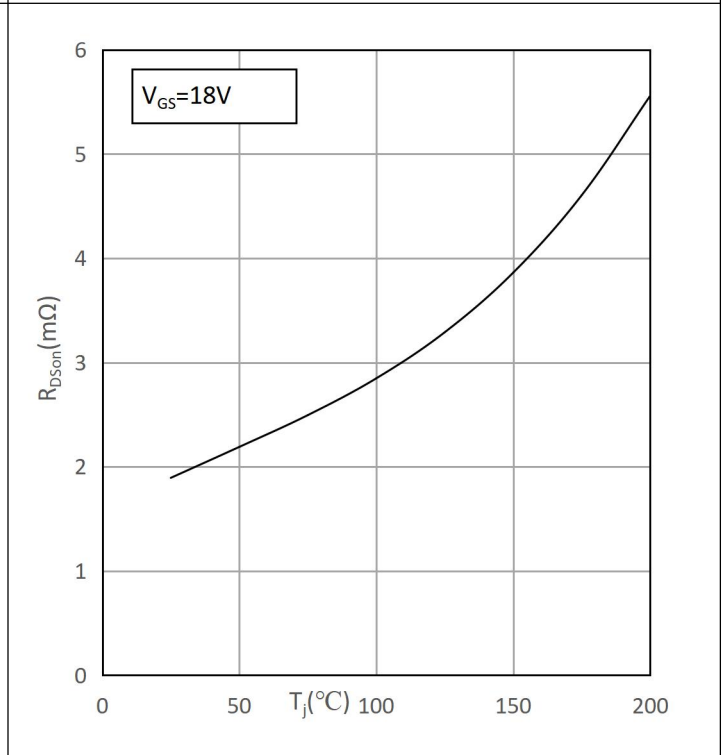

Fig.4 Drain-source On Resistance vs. Junction Temperature
图4: 漏极-源极内阻与温度的关系

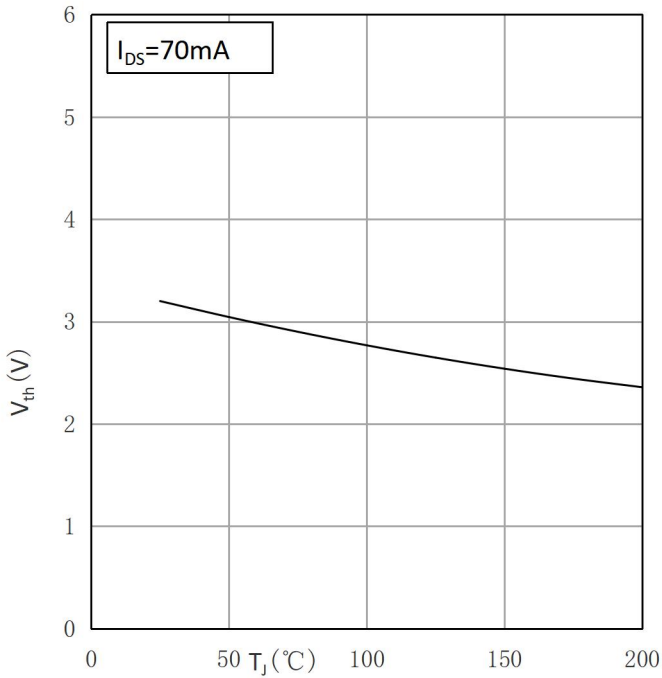

Fig.5 Gate Threshold Voltage vs. Junction Temperature

图5: 栅极阈值电压与温度的关系

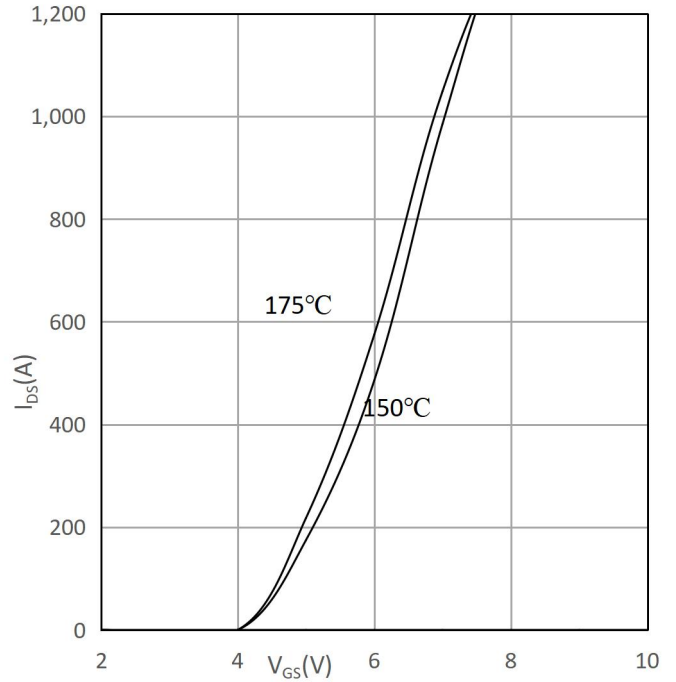

Fig.6 Typ. Transfer Characteristics($V_{DS}=20V$)

图6: 传输特性 ($V_{DS}=20V$)

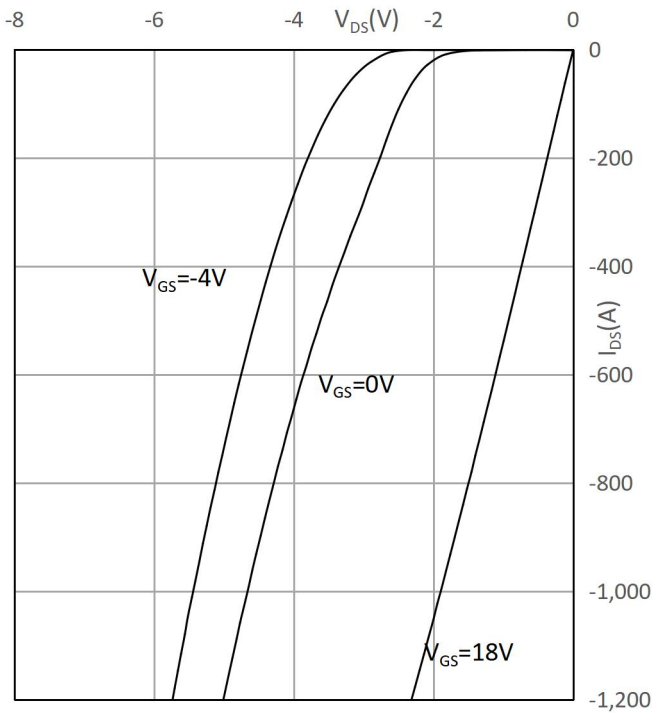

Fig.7 3rd Quadrant Characteristics($T_{vj}=25^{\circ}C$)

图 7: 第三象限特性($T_{vj}=25^{\circ}C$)

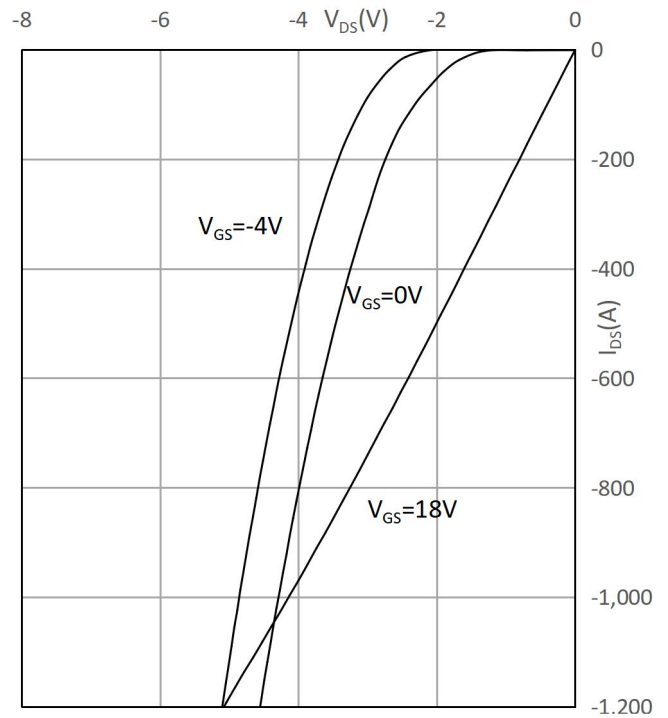

Fig.8 3rd Quadrant Characteristics($T_{vj}=150^{\circ}C$)

图 8: 第三象限特性($T_{vj}=150^{\circ}C$)

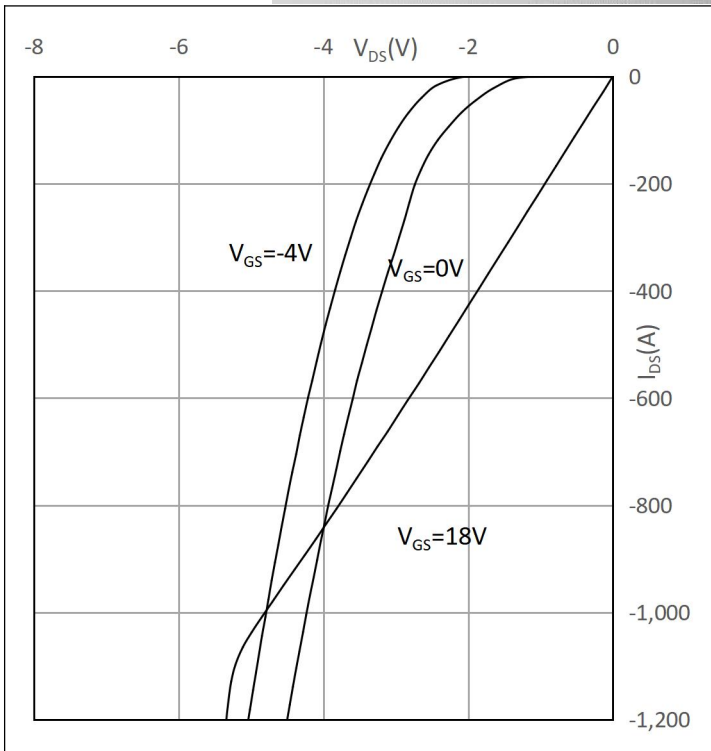

Fig.9 3rd Quadrant Characteristics($T_{vj}=175^{\circ}\text{C}$)
图 9: 第三象限特性($T_{vj}=175^{\circ}\text{C}$)

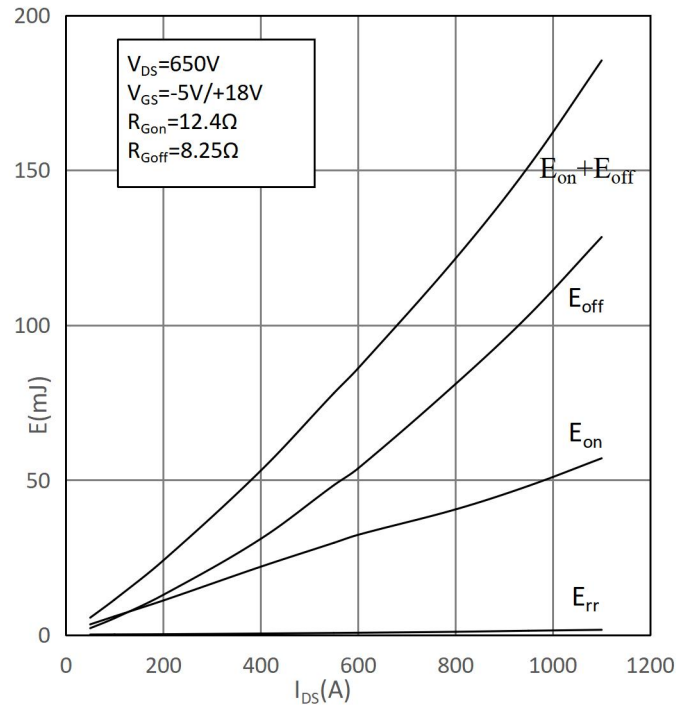

Fig.10: Switching Loss vs. Drain Current($T_{vj}=25^{\circ}\text{C}$)
图10: 开关损耗与漏极电流的关系($T_{vj}=25^{\circ}\text{C}$)

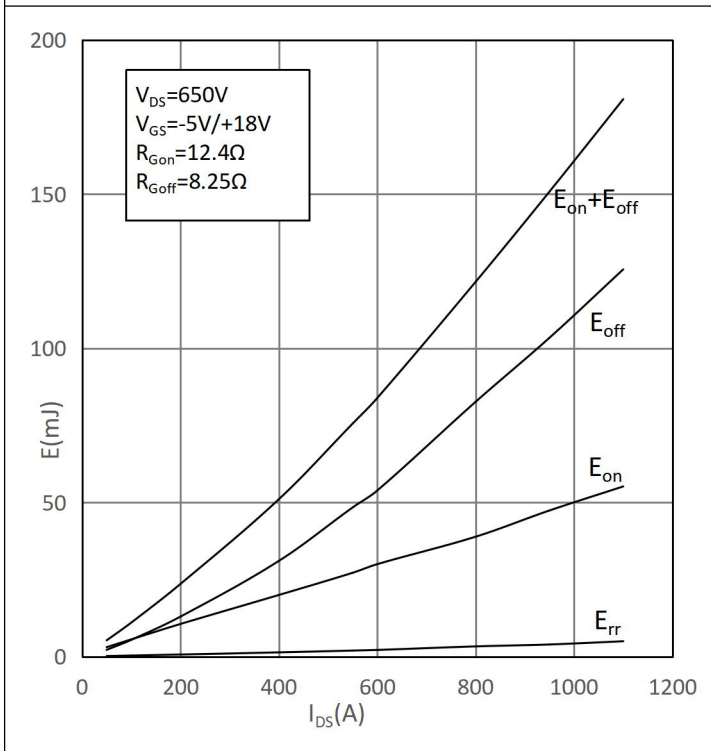

Fig.11 Switching Loss vs. Drain Current($T_{vj}=150^{\circ}\text{C}$)
图 11: 开关损耗与漏极电流的关系($T_{vj}=150^{\circ}\text{C}$)

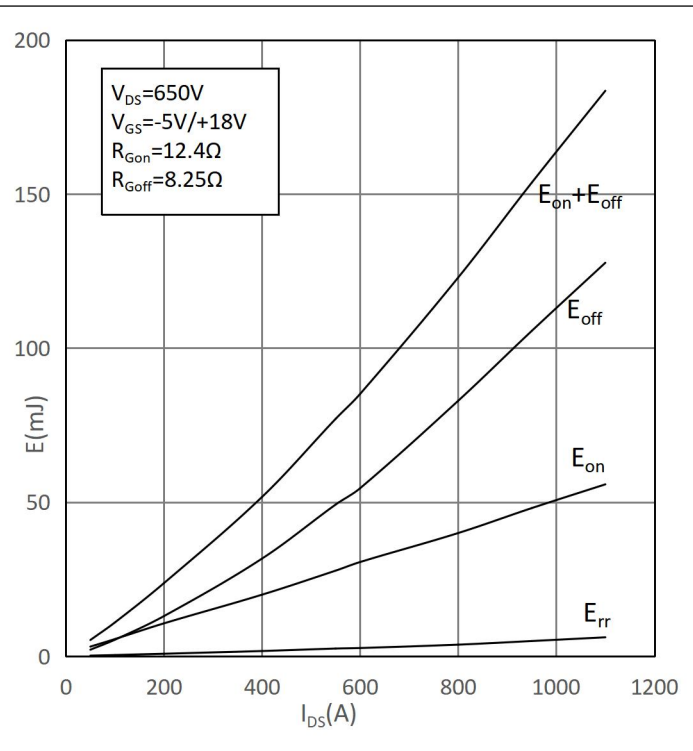

Fig.12 Switching Loss vs. Drain Current ($T_{vj}=175^{\circ}\text{C}$)
图12: 开关损耗与漏极电流的关系($T_{vj}=175^{\circ}\text{C}$)

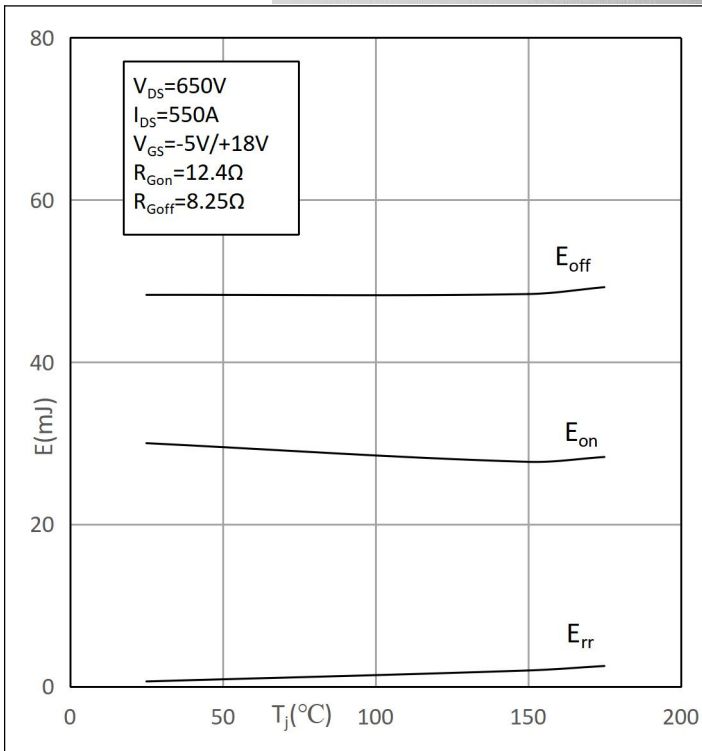

Fig.13 Switching Loss vs. Junction Temperature

图13: 开关损耗与结温关系

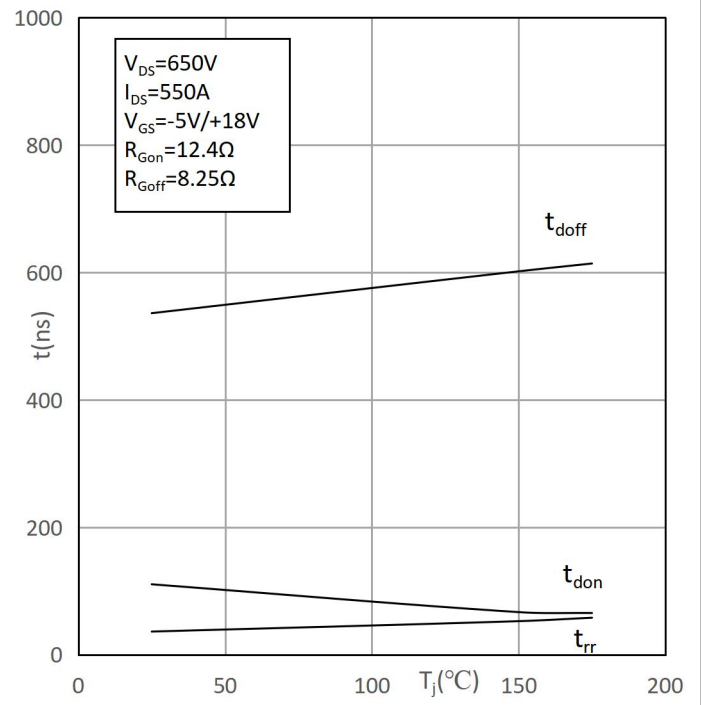

Fig.14 Switching Times vs. Junction Temperature

图14: 开关时间与结温关系

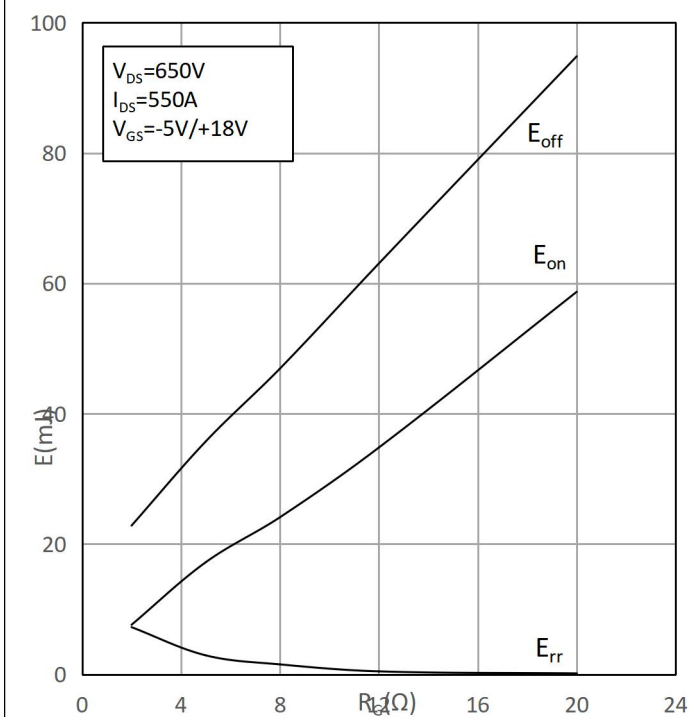

Fig.15 Switching Loss vs. Gate Resistor($T_{vj}=25^{\circ}\text{C}$)

图15: 开关损耗与门极电阻关系($T_{vj}=25^{\circ}\text{C}$)

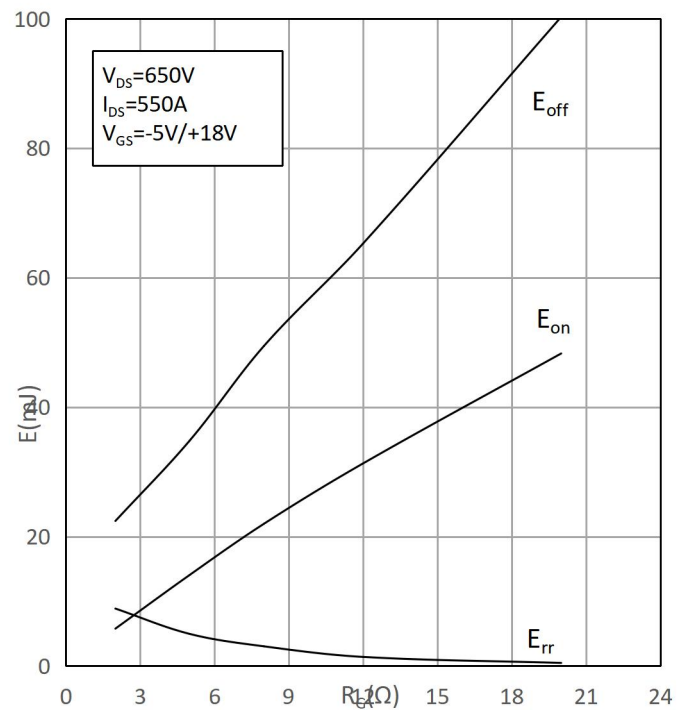

Fig.16 Switching Loss vs. Gate Resistor($T_{vj}=150^{\circ}\text{C}$)

图16: 开关损耗与门极电阻关系($T_{vj}=150^{\circ}\text{C}$)

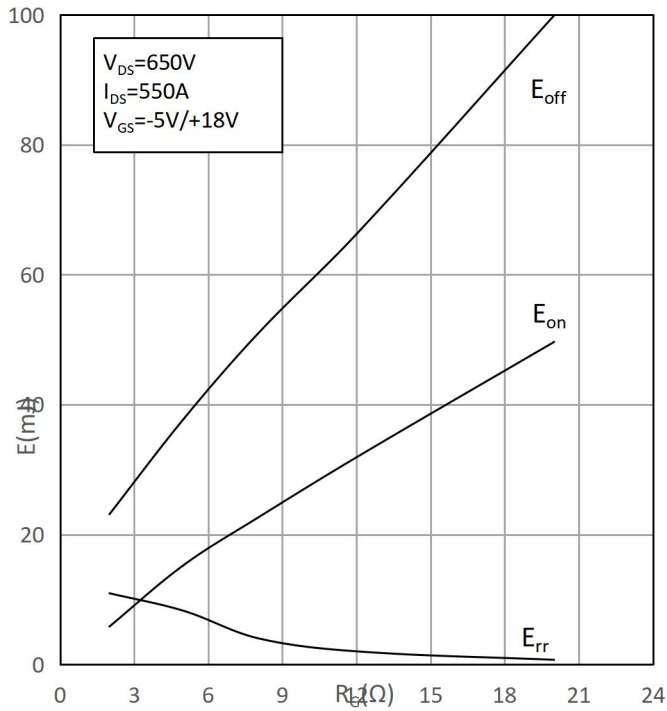

Fig.17 Switching Loss vs. Gate Resistor($T_{vj}=175^{\circ}\text{C}$)
图17: 开关损耗与门极电阻关系($T_{vj}=175^{\circ}\text{C}$)

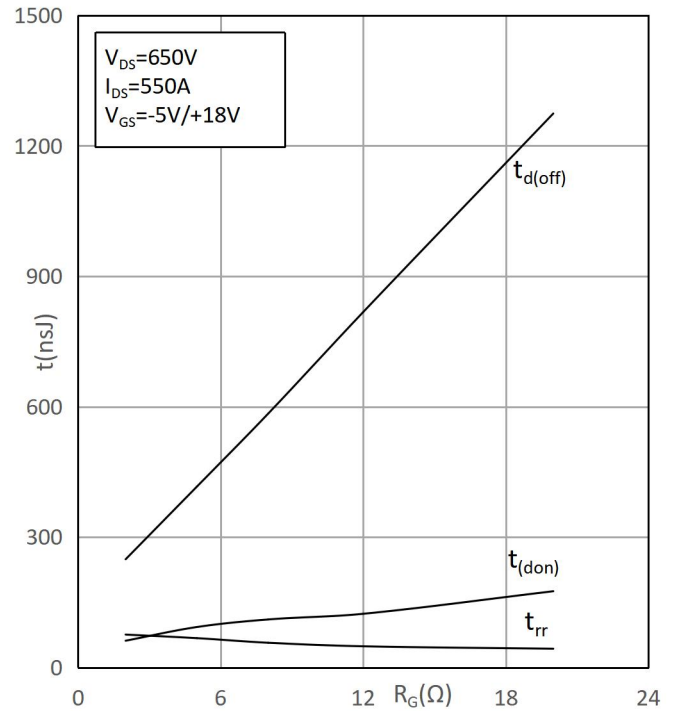

Fig.18 Switching Times vs. Gate Resistor ($T_{vj}=25^{\circ}\text{C}$)
图18: 开关时间与门极电阻关系($T_{vj}=25^{\circ}\text{C}$)

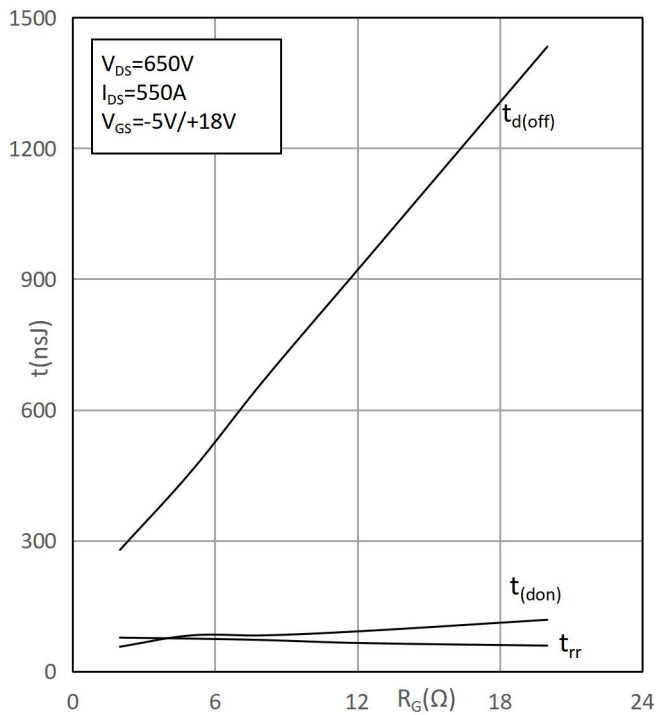

Fig.19 Switching Times vs. Gate Resistor($T_{vj}=150^{\circ}\text{C}$)
图19: 开关时间与门极电阻关系($T_{vj}=150^{\circ}\text{C}$)

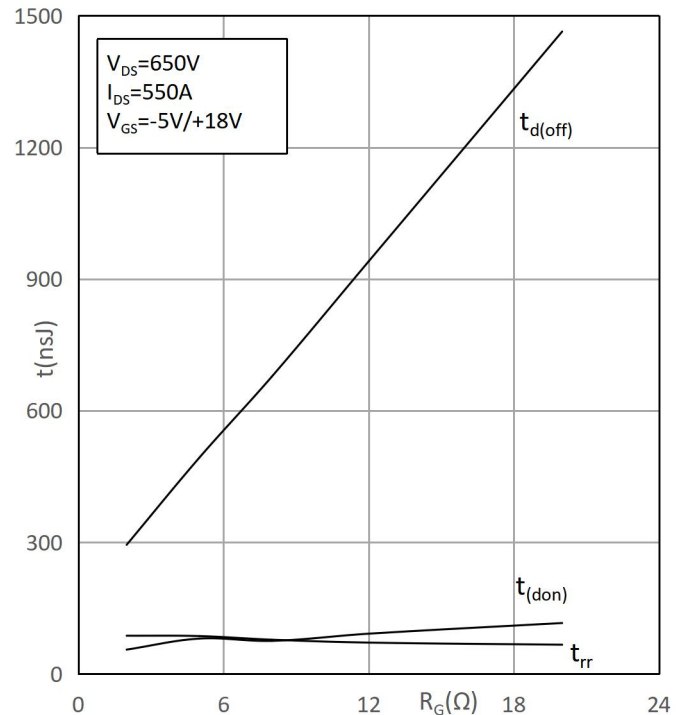

Fig.20 Switching Times vs. Gate Resistor($T_{vj}=175^{\circ}\text{C}$)
图20: 开关时间与门极电阻关系($T_{vj}=175^{\circ}\text{C}$)

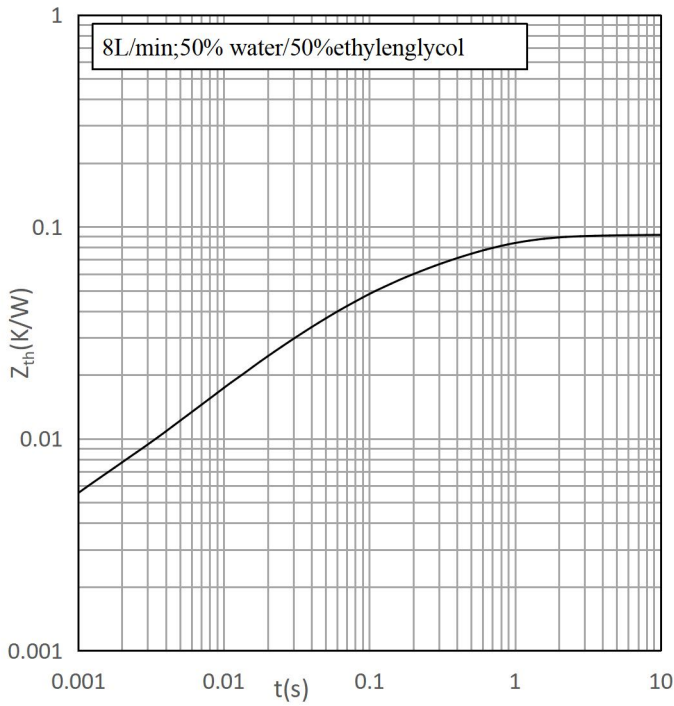

Fig.21 Typ.transient thermal impedance (MOSFET)
图21: 瞬态热阻抗(MOSFET)

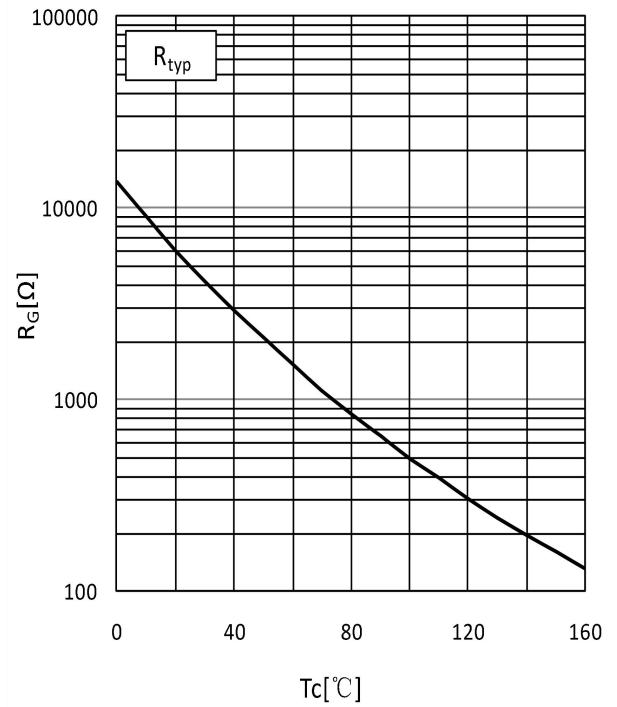
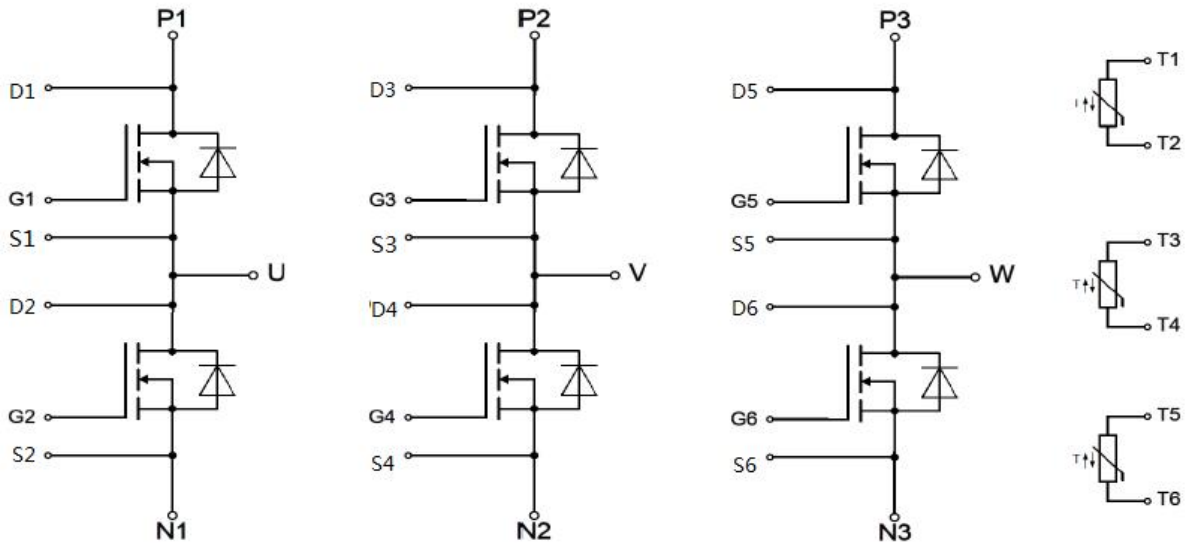
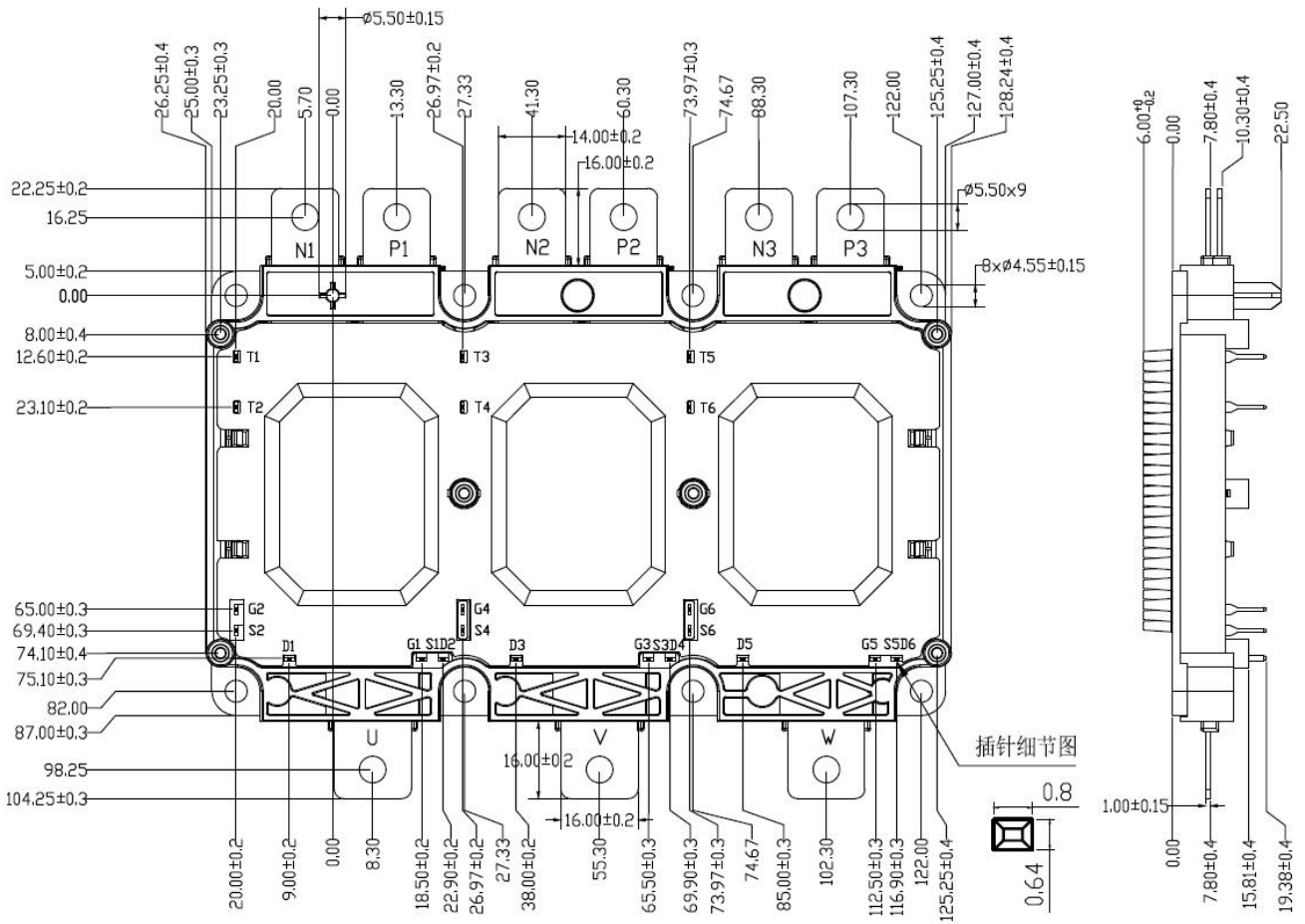

Fig.22 Typ. NTC-Temperature Characteristics
图22: NTC 热特性

□ Circuit Diagram/接线图



□ Package Outlines/封装尺寸



□ Attention

Correct and Safety Use of Power Module

Unsuitable operation (such as electrical, mechanical stress and so on) may lead to damage of power modules.

Please pay attention to the following descriptions and use BYD's IGBT modules according to the guidance.

During Transit:

- Tossing or dropping of a carton may damage devices inside.
- If a device gets wet with water, malfunctioning and failure may result. Special care should be taken during rain or snow to prevent the devices from getting wet.

Storage:

- The temperature and humidity of the storage place should be 5~35°C and 45~75% respectively. The performance and reliability of devices may be jeopardized if devices are stored in an environment far above or below the range indicated above.

Prolonged Storage:

- When storing devices more than one year, dehumidifying measures should be provided for the storage place. When using devices after a long period of storage, make sure to check the exterior of the devices is free from scratches, dirt, rust, and so on.

Operating Environment:

- Devices should not be exposed to water, organic solvents, corrosive gases, explosive gases, fine particles, or corrosive agents, since any of those can lead to a serious accident.

Anti-electrostatic Measures:

- Following precautions should be taken for gated devices to prevent static buildup which could damage the devices.

(1) Precautions against the device rupture caused by static electricity

Static electricity of human bodies and cartons and/or excessive voltage applied across the gate to emitter may damage and rupture devices. Sense-emitter and temperature-sensor are also vulnerable to excessive voltage. The basis of anti-electrostatic is suppression of build-up and quick dissipation of the charged electricity.

* Containers that are susceptible to static electricity should not be used for transit or for storage.

* Signal terminals to emitter should be always shorted with a carbon cloth or the like until right before a module is used. Never touch the signal terminals with bare hands.

* Always ground the equipment and your body during installation (after removing a carbon cloth or the like. It is advisable to cover the workstation and its surrounding floor with conductive mats and ground them.

* Use soldering irons with grounded tips.

BYD Semiconductor Company Limited exerts the greatest possible effort to ensure high quality and reliability. Nevertheless, semiconductor devices in general can malfunction or fail due to their inherent electrical sensitivity and vulnerability to physical stress. It is the responsibility of the buyer, when utilizing BYD products, to comply with the standards of safety in making a safe design for the entire system, including redundancy, fire-prevention measures, and malfunction prevention, to prevent any accidents, fires, or community damage that may ensue. In developing your designs, please ensure that BYD products are used within specified operating ranges as set forth in the most recent BYD products specifications.

□ 警示

功率模块安全正确的使用方法：

- 不当的操作（如电应力、机械应力等）可能导致模块损毁。请注意以下介绍，并根据指导来使用使用比亚迪IGBT模块。

运输过程中：

- 包装箱颠簸或坠落可能导致内部器件损毁。
- 器件遇水受潮将导致故障失效。在雨雪天气尤其要注意保护器件防止淋湿。

贮存：

- 贮存地点温度与湿度应分别控制在5~35°C和45~75%。如果贮存环境远高于或低于指示的变化范围，将危害器件的性能与可靠性。

长期贮存：

- 当存储器件时间超过一年，贮存地点应当采取去湿措施。器件经过长期存放使用时，检查器件确保外观没有刮伤，灰尘，锈迹等。

应用环境：

- 器件不应当暴露在水，有机溶剂，腐蚀性气体、易燃易爆性气体，微尘，腐蚀性药剂中，上述任何一种情况都会导致严重事故。

防静电措施：

- 带栅极器件应采取以下预警来防止可以损毁器件的静电生成。

(1) 预防措施可以防止静电击穿器件。

*门极与发射极间产生的人体静电、包装箱静电和过电压将损毁或击穿器件。采样发射极和温度传感器同样容易受到过压损毁。

防静电底板可以抑制电荷生成并快速耗散。

* 不要用易受静电影响的容器运输或贮存器件。

* 发射极信号端子应一直用碳纤维布或类似物短接直到模块使用前。任何情况下不要徒手碰触信号端子。

*安装过程中始终保持设备和你的身体接地(移除碳纤维布或类似物后)。用导电垫覆盖工作地点及周围地板并使其接地。

* 使用接地的烙铁头。

比亚迪半导体股份有限公司（简称BYD）致力于产品的高性能和高可靠性。然而，半导体器件一般会因为其固有的对电荷敏感性和易受物理应力损坏的特点，而发生故障和失效。当用户购买BYD的产品时，用户有责任按照安全标准来为整个系统做出安全的设计来防止任何事故，火灾或继而引起的危害公共安全，包括设计的冗余、防火措施、故障预防。请改善您的设计，确保BYD的产品在额定范围内使用并参考最新的BYD产品规格书。