

概述

BIP60006B 是比亚迪公司最新设计开发的紧凑型全塑封智能功率模块（IPM-Intelligent Power Module）。该产品内部集成高可靠性的高压栅极驱动电路，内置带限流电阻的自举二极管，集成欠压、过流和使能关断等保护功能，自带温度输出功能，提供了优异的保护和较宽的安全工作范围，是小功率白色家电的理想选择。由于采用了分立的负端子，可独立监测逆变器的每一相电流。该产品适用于较低功率的变频驱动，如空调风机、冰箱和洗衣机等

General Description

BIP60006B is a compact all-plastic package intelligent power module designed and developed by BYD Company. The product integrates high reliability high voltage gate drive circuit, built-in bootstrap diode with current limiting resistance, integrated undervoltage, overcurrent and enable shut-down protection functions, temperature output function, provides excellent protection and wide safe working range, is an ideal choice for small power white goods. Because of the use of discrete negative terminals, the inverter can be independently monitored each phase current. The product is suitable for low power variable frequency drives, such as air conditioning fans, refrigerators and washing machines

产品特性

- 结构紧凑，全塑封设计
- 采用低损耗BYD IGBT 5.0芯片
- 内置带自举二极管的高压栅极驱动（HVIC）
- 内置欠压保护、过流保护和使能关断功能
- 内置温度电压输出功能
- 内置双高电平输入互锁功能
- 输入高电平有效，兼容3.3V、5V电压
- 分立的三相直流负端，可独立检测相电流

Features

- Compact structure, fully plastic package design
- Low loss BYD IGBT 5.0 chip
- Built in high-voltage gate drive with bootstrap diode
- Built in undervoltage protection, overcurrent protection and enable shutdown functions
- Built in temperature voltage output function
- Built in dual high level input interlocking function
- The input high level is valid and compatible with 3.3V and 5V voltages
- Discrete three-phase DC negative terminal, which can independently detect phase current

应用领域

- 空调风机
- 冰箱
- 洗衣机

Applications

- Air conditioning fan
- Refrigerator
- Washing machine

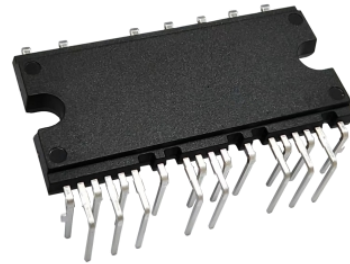

封装/Package

DIP25-B

内部等效电路/Internal Equivalent Circuit



图1. 内部等效电路

Fig 1. Internal Equivalent Circuit

引脚布局/Pin Configuration

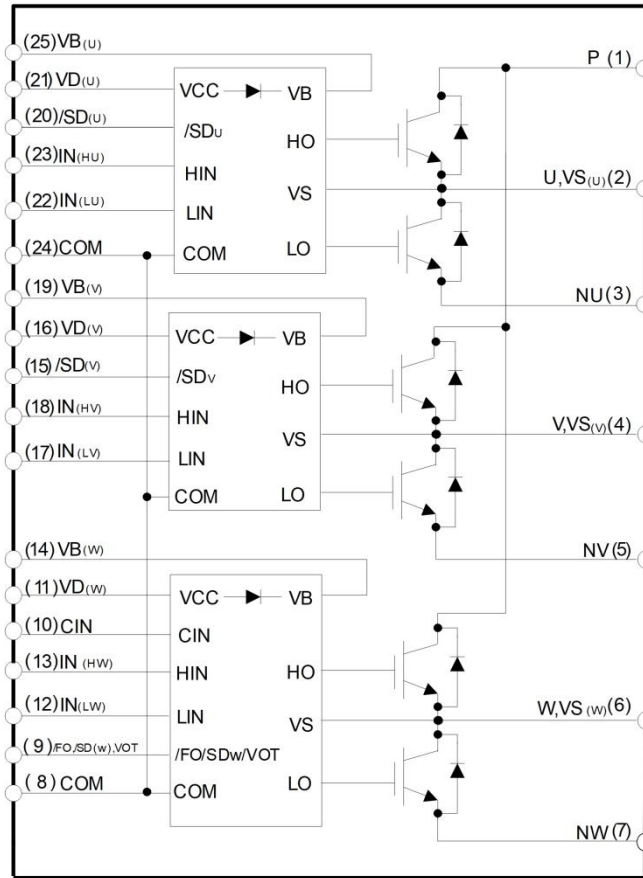

图 2. 引脚布局图(top view)

Fig 2. Pin Configuration(Top View)

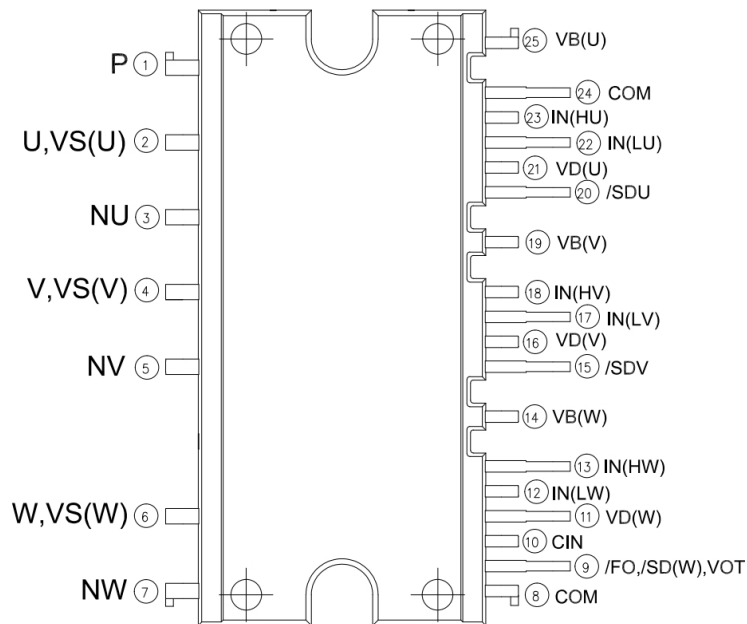

引脚描述/Pin Descriptions

引脚号 Pin	引脚名 Name	描述 Descriptions
1	P	直流正端 DC positive terminal
2	U,VS(U)	U 相输出端和 U 相高边驱动电源地 output for U phase and power GND for high side U phase
3	NU	U 相直流负端 DC negative terminal for U phase
4	V,VS(V)	V 相输出端和 V 相高边驱动电源地 output for V phase and power GND for high side V phase
5	NV	V 相直流负端 DC negative terminal for V phase
6	W,VS(W)	W 相输出端和 W 相高边驱动电源地 output for W phase and power GND for high side W phase
7	NW	W 相直流负端 DC negative terminal for W phase
8	COM	模块公共电源地 Common power supply GND
9	/FO,/SDW,VOT	故障输出, W 相使能关断输入, 驱动温度输出 Fault Output, Shut-down Input for W Phase, Temperature output of drive IC
10	CIN	过流保护输入端 Shut-down Input for over current protection
11	VD(W)	W 相 IC 和低边 IGBT 驱动供电端 W phase IC and low side IGBT drive power supply terminal
12	IN(LW)	W 相低边信号输入端 W phase low side signal input terminal
13	IN(HW)	W 相高边信号输入端 W phase high side signal input terminal
14	VB(W)	W 相高边驱动电源端 Drive power terminal for high side W phase
15	/SDV	V 相使能关断输入 Shut-down Input for V Phase
16	VD(V)	V 相 IC 和低边 IGBT 驱动供电端 V phase IC and low side IGBT drive power supply terminal
17	IN(LV)	V 相低边信号输入端 V phase low side signal input terminal
18	IN(HV)	V 相高边信号输入端 V phase high side signal input terminal
19	VB(V)	V 相高边驱动电源端 Drive power terminal for high side V phase
20	/SDU	U 相使能关断输入 Shut-down Input for U Phase
21	VD(U)	U 相 IC 和低边 IGBT 驱动供电端 U phase IC and low side IGBT drive power supply terminal



22	IN(LU)	U 相低边信号输入端 U phase low side signal input terminal
23	IN(HU)	U 相高边信号输入端 U phase high side signal input terminal
24	COM	模块公共电源地 Common power supply GND
25	VB(U)	U 相高边驱动电源端 Drive power terminal for high side U phase

最大绝对额定值/Absolute Maximum Ratings

($T_J=25^{\circ}\text{C}$,除非另外注明/unless otherwise noted)

逆变器部分/Inverter Part

符号 Symbol	参数 Parameter	工作条件 Conditions	额定值 Ratings	单位 Units
V_{PN}	电源电压 Supply voltage	施加在 P- N_U , N_V , N_W 之间 Applied between P- N_U , N_V , N_W	450	V
$V_{PN}(\text{surge})$	电源 (浪涌) Supply voltage (surge)	施加在 P- N_U , N_V , N_W 之间 Applied between P- N_U , N_V , N_W	500	V
V_{CES}	集电极-发射极之间电压 Collector-emitter voltage	$V_{GE}=0\text{V}$, $I_C=0.1\text{mA}$, $T_J=25^{\circ}\text{C}$	600	V
$\pm I_C$	单颗 IGBT 集电极持续电流 Each IGBT collector current	$T_C = 25^{\circ}\text{C}$, $T_J \leq 150^{\circ}\text{C}$	6	A
$\pm I_{CP}$	单颗 IGBT 集电极峰值电流 Each IGBT collector peak current	$T_C = 25^{\circ}\text{C}$, $T_J \leq 150^{\circ}\text{C}$, 低于 1ms 的脉冲宽度 $T_C = 25^{\circ}\text{C}$, $T_J \leq 150^{\circ}\text{C}$, Under 1ms Pulse Width	12	A
P_C	集电极功耗 Collector dissipation	$T_C = 25^{\circ}\text{C}$, 每一片 $T_C = 25^{\circ}\text{C}$, per 1 chip	21	W
T_J	结温 Junction temperature	(注 1/Note 1)	-40~+150	$^{\circ}\text{C}$

注 1: 智能功率模块中集成的功率芯片的最大结温额定值为 150°C ($@T_C \leq 100^{\circ}\text{C}$)。但是, 为了确保智能功率模块的安全工作, 平均结温应限制为 $T_{J(\text{ave})} \leq 125^{\circ}\text{C}$ ($@T_C \leq 100^{\circ}\text{C}$)。

Note 1: The maximum junction temperature rating of the power chips integrated within the IPM is 150°C ($@T_C \leq 100^{\circ}\text{C}$). However, to ensure safe operation of the IPM, the average junction temperature should be limited to $T_{J(\text{ave})} \leq 125^{\circ}\text{C}$ ($@T_C \leq 100^{\circ}\text{C}$).

控制部分/Control Part

符号 Symbol	参数 Parameter	工作条件 Conditions	额定值 Ratings	单位 Units
V_D	控制电源电压 Control Supply Voltage	施加在 $V_{D(U)}$, $V_{D(V)}$, $V_{D(W)}$ -COM 之间 Applied between $V_{D(U)}$, $V_{D(V)}$, $V_{D(W)}$ -COM	-0.3~20	V
V_{BS}	高边控制电源电压 High side control supply voltage	施加在 $V_{B(U)}$ -U, $V_{B(V)}$ -V, $V_{B(W)}$ -W 之间 Applied between $V_{B(U)}$ -U, $V_{B(V)}$ -V, $V_{B(W)}$ -W	-0.3~20	V
V_{IN}	输入电压 Input voltage	施加在 $IN_{(HU)}$, $IN_{(LU)}$, $IN_{(HV)}$, $IN_{(LV)}$, $IN_{(HW)}$, $IN_{(LW)}$ -COM 之间 Applied between $IN_{(HU)}$, $IN_{(LU)}$, $IN_{(HV)}$, $IN_{(LV)}$, $IN_{(HW)}$, $IN_{(LW)}$ -COM	$-0.3 \sim V_D + 0.3$	V



V_{FO}	故障输出电压 Fault output voltage	施加在/F _O /S _{DW} ,V _{OT} -COM 之间 Applied between /F _O /S _{DW} ,V _{OT} -COM	-0.3~V _D +0.3	V
I_{FO}	故障输出电流 Fault output current	在引脚/F _O /S _{DW} ,V _{OT} 处灌电流 Sink current at /F _O /S _{DW} ,V _{OT} terminal	2	mA
V_{CIN}	过流检测输入电压 Over Current sensing input voltage	施加在 C _{IN} -COM 之间 Applied between C _{IN} -COM	-0.3~V _D +0.3	V

整个系统/Total System

符号 Symbol	参数 Parameter	工作条件 Conditions	额定值 Ratings	单位 Units
$V_{PN(Prot)}$	自保护电源电压限制(短路保护能力) Self protection supply voltage limit (short circuit protection capability)	V _D = 13.5~16.5V, T _J = 125°C, 非重复性, 小于 5 μs V _D = 13.5~16.5V, inverter part T _J = 150°C, non-repetitive, less than 5 μs	400	V
T _C	模块壳体工作温度 Module case operation temperature	-40°C ≤ T _J ≤ 150°C, 图 2 (Fig 2.)	-40~+125	°C
T _{STG}	存储/保存温度 Storage temperature		-40~+125	°C
V _{ISO}	绝缘电压/Isolation voltage	60Hz, 正弦波形, 交流 1 分钟, 所有引脚与 DBC 之间 60Hz, sinusoidal, AC 1 minute, connection pins to heat sink plate	1650	Vrms

热阻/Thermal Resistance

符号 Symbol	参数 Parameter	工作条件 Conditions	最小值 Min.	典型值 Typ.	最大值 Max.	单位 Units
$R_{th(j-c)Q}$	结点-壳体的热阻	逆变器 IGBT 部分 (每 1/6 模块) Inverter IGBT part (per 1/6 module)	-	-	5.8	°C/W
$R_{th(j-c)F}$	Junction to case thermal resistance	逆变器 FRD 部分 (每 1/6 模块) Inverter FRD part (per 1/6 module)	-	-	7.4	°C/W

电气特性/Electrical Characteristics

(T_J=25°C,除非另外注明/unless otherwise noted)

逆变器部分/Inverter Part

符号 Symbol	参数说明 Parameter	工作条件 Conditions	最小值 Min.	典型值 Typ.	最大值 Max.	单位 Units
$V_{CE(SAT)}$	集电极-发射极间饱和电压 Collector-emitter saturation voltage	V _D =V _{BS} =15V, V _{IN} =5V, I _C =6A, T _J =25°C	-	1.7	2.2	V
V_F	FRD 正向电压 FRD forward voltage	V _{IN} =0V, I _F =6A, T _J =25°C	-	1.8	2.3	
I _{CES}	集电极-发射极间漏电流 Collector-Emitter leakage current	V _{CE} =V _{CES} , V _{GE} =0V, T _J =25°C	-	-	0.1	mA



高边 High side	t_{ON}	开通时间 Turn-on time	$V_{PN}=300V,$ $V_D=V_{BS}=15V, I_c = 6A,$ $V_{IN} = 0\sim 5V, T_J = 25^\circ C,$ 感性负载 (注 2) Inductive load (Note 2)	-	450	-	ns
	$t_{C(ON)}$	开通交叉时间 Turn-on across time		-	130	-	ns
	t_{rr}	反向恢复时间 Reverse recovery time		-	85	-	ns
	t_{OFF}	关断时间 Turn-off time		-	550	-	ns
	$t_{C(OFF)}$	关断交叉时间 Turn-off across time		-	90	-	ns
低边 Low side	t_{ON}	开通时间 Turn-on time		-	460	-	ns
	$t_{C(ON)}$	开通交叉时间 Turn-on across time		-	135	-	ns
	t_{rr}	反向恢复时间 Reverse recovery time		-	90	-	ns
	t_{OFF}	关断时间 Turn-off time		-	560	-	ns
	$t_{C(OFF)}$	关断交叉时间 Turn-off across time		-	100	-	ns

注 2: t_{ON} 和 t_{OFF} 包括模块内部驱动集成电路(IC) 的传输延迟时间。 $t_{C(ON)}$ 和 $t_{C(OFF)}$ 指在内部给定的门极驱动条件下, IGBT 本身的切换时间。详细信息, 参考图 3。

Note 2 : t_{on} and t_{off} include the propagation delay time of the internal drive IC. $t_{c(on)}$ and $t_{c(off)}$ are the switching time of IGBT itself under the given gate driving condition internally. See figure 3.



图 3.开关时间定义
Fig 3. Switching Time Definition

控制部分/Control Part

符号 Symbol	参数 Parameter	工作条件 Conditions	最小值 Min.	典型值 Typ.	最大值 Max.	单位 Units
I_{QD}	V_D 静态电流 Quiescent V_D supply current	$V_{D(U,V,W)}=15V,$ $I_N(HU,HV,HW,LU,LV, LW)=0V$	---	---	1.0	mA
I_{QBS}	V_{BS} 静态电流 Quiescent V_{BS} supply current	$V_{BS(U,V,W)}=15V,$ $I_N(HU,HV,HW)=0V$	---	---	150	μA
$V_{CIN(ref)}$	短路保护触发电压 Short circuit trip level	$V_{D(U,V,W)}=15V$	0.43	0.48	0.53	V

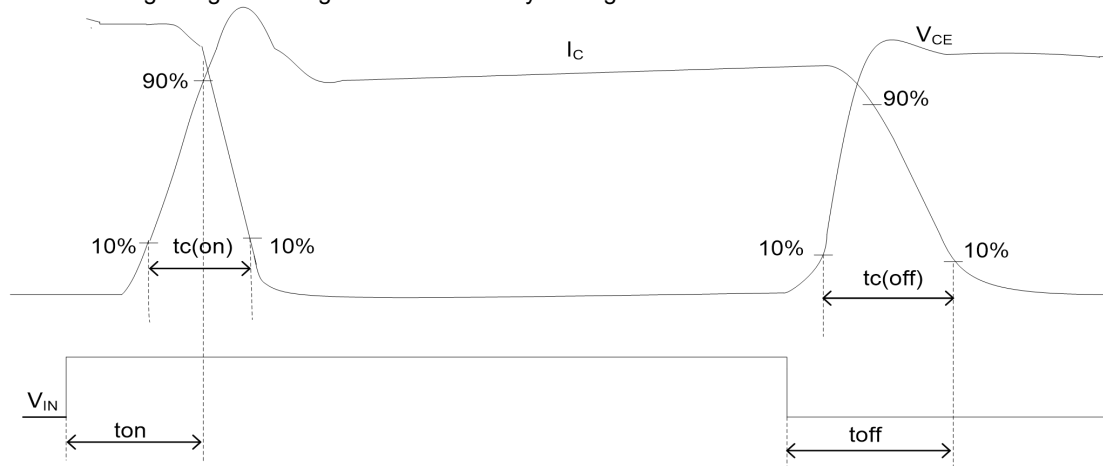

UV _{DD}	供电电源欠压保护 Supply circuit under-voltage protection	检测电平（低边） Detection level（LS）	9.0	10.0	11.0	V
UV _{DR}		复位电平（低边） Rest level（LS）	10.0	11.0	12.0	V
UV _{BSD}		检测电平（高边） Detection level（HS）	9.0	10.0	11.0	V
UV _{BSR}		复位电平（高边） Rest level（HS）	10.0	11.0	12.0	V
I _{FO-T}	温度输出电流 HVIC Temperature Sensing Current	V _{D(W)} = V _{B(W)} = 15 V, T _{HVIC} = 25 °C	---	110	---	μ A
		V _{D(W)} = V _{B(W)} = 15 V, T _{HVIC} = 100 °C	---	279	---	μ A
V _{FO-T}	温度输出电压 HVIC Temperature Sensing Current	V _{D(W)} = V _{B(W)} = 15 V, T _{HVIC} = 25 °C, 6.8 kΩ to 5 V Pull-up	---	4.25	---	V
		V _{D(W)} = V _{B(W)} = 15 V, T _{HVIC} = 100 °C, 6.8 kΩ to 5 V Pull-up	---	3.1	---	V
t _{FO}	故障信号输出脉冲宽度 Fault-out pulse width		40	---	---	μ s
V _{FSDR}	使能关断复位电压 Shut-down Reset level	施加在 /FO-COM Applied between /FO-COM	---	---	2.4	V
V _{FSDD}	使能关断检测电压 Shut-down Detection level		0.8	---	---	V
V _{IN(ON)}	导通阈值电压 ON threshold voltage	施加在 IN _(HU) , IN _(LU) , IN _(HV) , IN _(LV) , IN _(HW) , IN _(LW) -COM 之间 Applied between IN _(HU) , IN _(LU) , IN _(HV) , IN _(LV) , IN _(HW) , IN _(LW) -COM	---	---	3.0	V
V _{IN(OFF)}	关断阈值电压 OFF threshold voltage		0.8	---	---	
R _{BS(ON)}	自举二极管限流电阻 BS driver ON resistance	V _{D(U,V,W)} = 15V	---	100	---	Ω

注 3 :只有下桥驱动具有短路保护和过温保护功能:

Note3: Only low side has short circuit protection and over temperature protection.

温度模拟输出/ Temperature analog output



图 4.W相HVIC温度输出特性
Fig 4. W-phase HVIC temperature output

机械特性和额定值/Mechanical Characteristics and Ratings

符号 Symbol	工作条件 Conditions	最小值 Min.	典型值 Typ.	最大值 Max.	单位 Units
安装扭矩 Mounting torque	安装螺钉: -M3 Mounting screw: - M3 推荐选用: 0.62N·m Recommended 0.62N.m	0.6	0.7	0.8	N·m
重量 Weight		---	3.9	---	g
器件平面度 Device flatness	参见图 5 (See Fig 5)	-50	---	100	μm

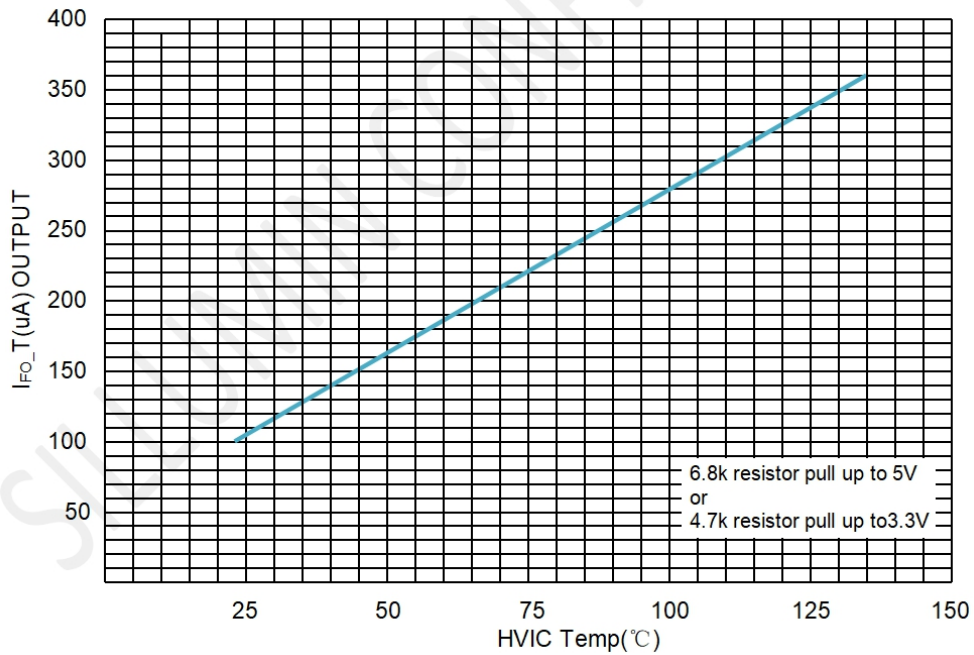

图 5. 平面度测量位置
Fig 5. Flatness Measurement Position



推荐工作条件/Recommended Operating Conditions

符号 Symbol	参数 Parameter	工作条件 Conditions	最小值 Min.	典型值 Typ.	最大值 Max.	单位 Units
V_{PN}	电源电压 Supply voltage	施加在 P- N_U , N_V , N_W 之间 Applied between P - N_U , N_V , N_W	---	300	400	V
V_D	控制电源电压 Control supply voltage	施加在 $V_{D(U)}$, $V_{D(V)}$, $V_{D(W)}$ -COM 之间 Applied between $V_{D(U)}$, $V_{D(V)}$, $V_{D(W)}$ -COM	13.5	15.0	16.5	
V_{BS}	高边控制电源电压 High side control supply voltage	施加在 $V_{B(U)-U}$, $V_{B(V)-V}$, $V_{B(W)-W}$ 之间 Applied between $V_{B(U)-U}$, $V_{B(V)-V}$, $V_{B(W)-W}$	13.5	15.0	18.5	
dV_D / dt , dV_{BS} / dt	控制电源电压波动 Control supply variation		-1	---	1	V/ μ s
t_{DEAD}	防止桥臂直通的死区时间 Blanking time for preventing arm-short	适用于每个输入信号 For each input signal	1.0	---	---	μ s
f_{PWM}	PWM 输入信号 PWM input signal	$-20^{\circ}\text{C} \leq T_C \leq 100^{\circ}\text{C}$, $-40^{\circ}\text{C} \leq T_J \leq 125^{\circ}\text{C}$	---	---	20	kHz
V_{SEN}	电流检测产生的电压 Voltage for current sensing	施加在 N_U , N_V , N_W -COM 之间 (包括浪涌电压) Applied between N_U , N_V , N_W -COM (Including surge voltage)	-4	---	4	V
$P_{WIN(ON)}$	最小输入脉宽 Minimum input pulse width	$V_D = V_{BS} = 15\text{V}$	0.7	---	---	μ s
$P_{WIN(OFF)}$			0.7	---	---	

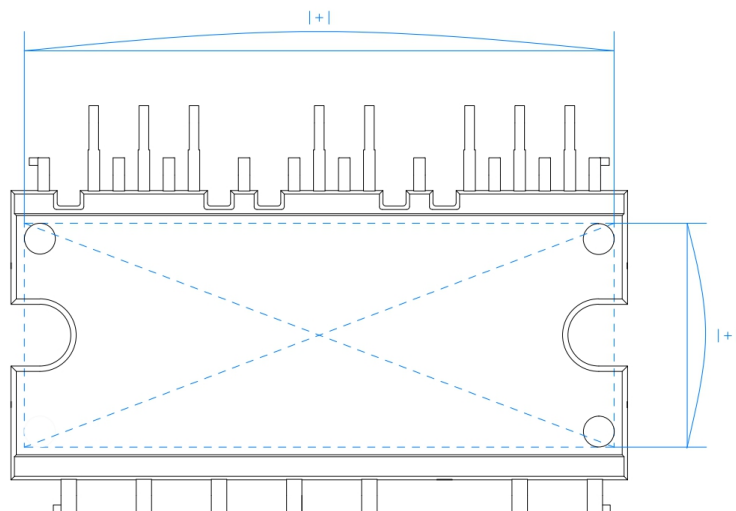
IPM 保护功能时序图/Time charts of IPM Protection Function

低边欠压保护/Under-Voltage Protection of low-side



图 6.低边欠压保护

Fig 6. Under-Voltage Protection of low-side

- a1: 控制电源电压升高: 电压升高至 U_{VDR} 后, 当施加下一个输入时, 电路开始工作;
Control supply voltage rises: after the voltage rises U_{VDR} , the circuits start to operate when next input is applied.
- a2: 正常运行: IGBT 导通和过电流;
Normal operation: IGBT ON and carrying current.
- a3: 欠压检测 (U_{VDD});
Under-voltage detection (U_{VDD}).
- a4: IGBT 都关闭;
ALL IGBT OFF.
- a5: 故障输出开始
Fault output starts.
- a6: 欠压保护复位(U_{VDR})
Under-voltage reset (U_{VDR}).
- a7: 正常运行: IGBT 导通和过电流;
Normal operation: IGBT ON and carrying current.

高边欠压保护/Under-Voltage Protection of high-side

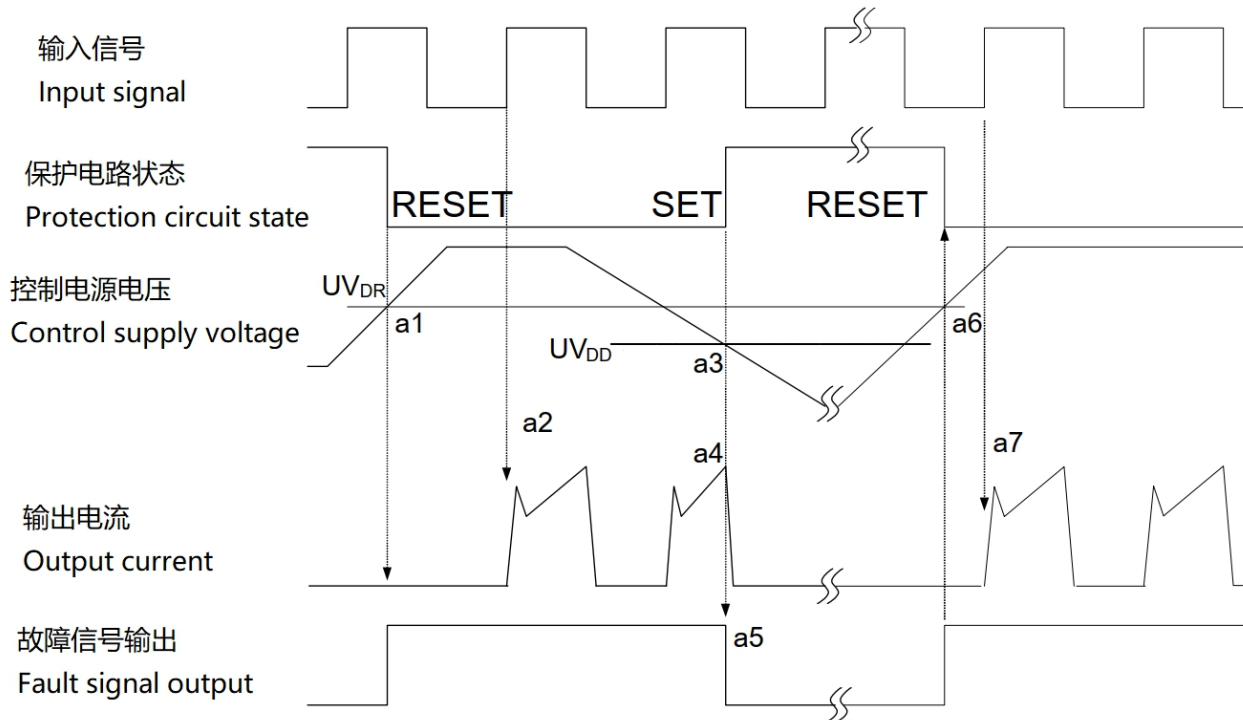

图 7.高边欠压保护

Fig 7. Under-Voltage Protection of high-side

- b1: 控制电源电压升高: 电压升高至 U_{VBSR} 后, 当施加下一个输入时, 电路开始工作;
Control supply voltage rises: after the voltage rises U_{VBSR} , the circuits start to operate when next input is applied.
- b2: 正常运行: IGBT 导通和过电流;
Normal operation: IGBT ON and carrying current.
- b3: 欠压检测 (U_{VBSD});
Under-voltage detection (U_{VBSD}).
- b4: IGBT 都关闭,但没有故障信号输出
IGBT OFF, but there is no fault output signal.
- b5: 欠压保护复位(U_{VBSR})
Under-voltage reset (U_{VBSR}).
- b6: 正常运行: IGBT 导通和过电流;
Normal operation: IGBT ON and carrying current.

内部锁定功能/Inter lock function

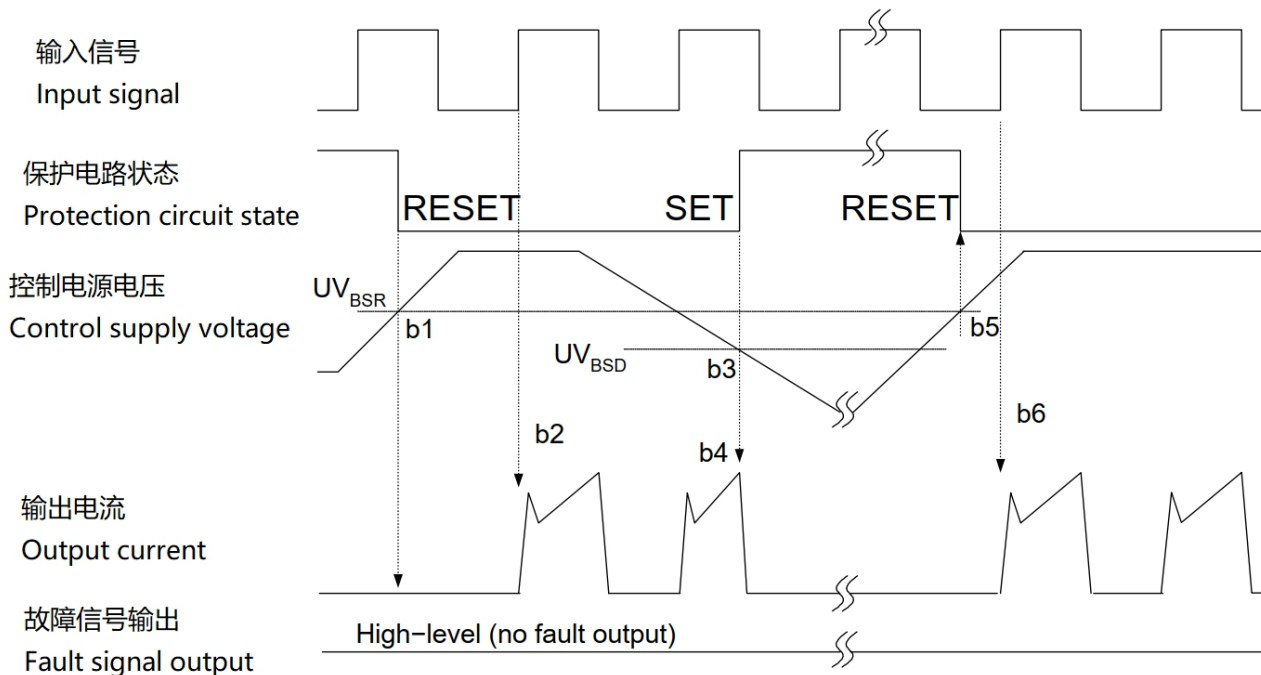

图 8.内部锁定功能
Fig 8. Inter lock function

- d1: 高边先输入信号先有效，即先输入先有效
High-side first-input-first-output mode
- d2: 低边输入有噪声脉冲，LO 无输出信号
Low-side noise mode, no LO output signal
- d3: 高边输入有噪声脉冲，HO 无输出信号
High-side noise mode, no HO output signal
- d4: 低边先输入信号先有效，即先输入先有效
Low-side first-input-first-output mode
- d5: LIN 和 HIN 同时输入时，无 HO 输出信号
In-phase mode, no HO output signal

过流保护时序/Fault-Out by Over Current Protection

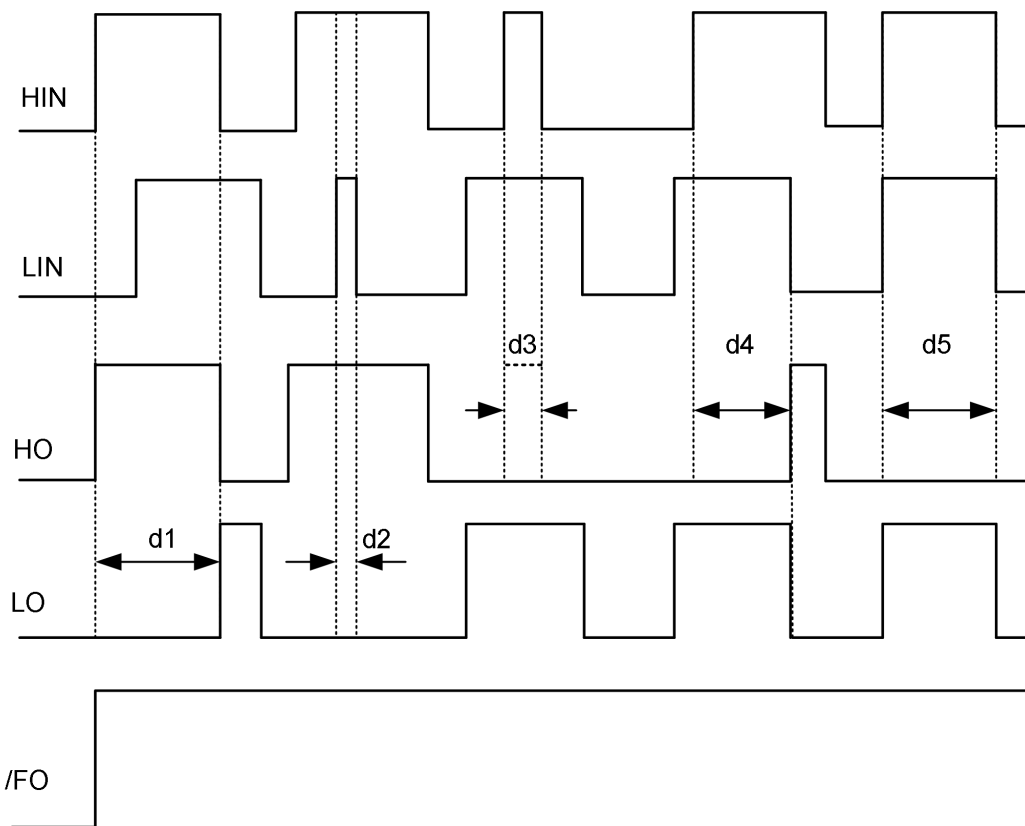

图 9.过流保护时序

Fig 9.Fault-Out by Over Current Protection

- HIN: 高边输入信号
High-side input signal
- LIN: 低边输入信号
Low-side input signal
- HO: 高边输出信号
High-side output signal
- LO: 低边输出信号
Low-side output signal
- CSC: 过流保护检测输入
Over current detection input
- /FO: 故障输出
Fault output signal

使能关断时序/External Shutdown Control

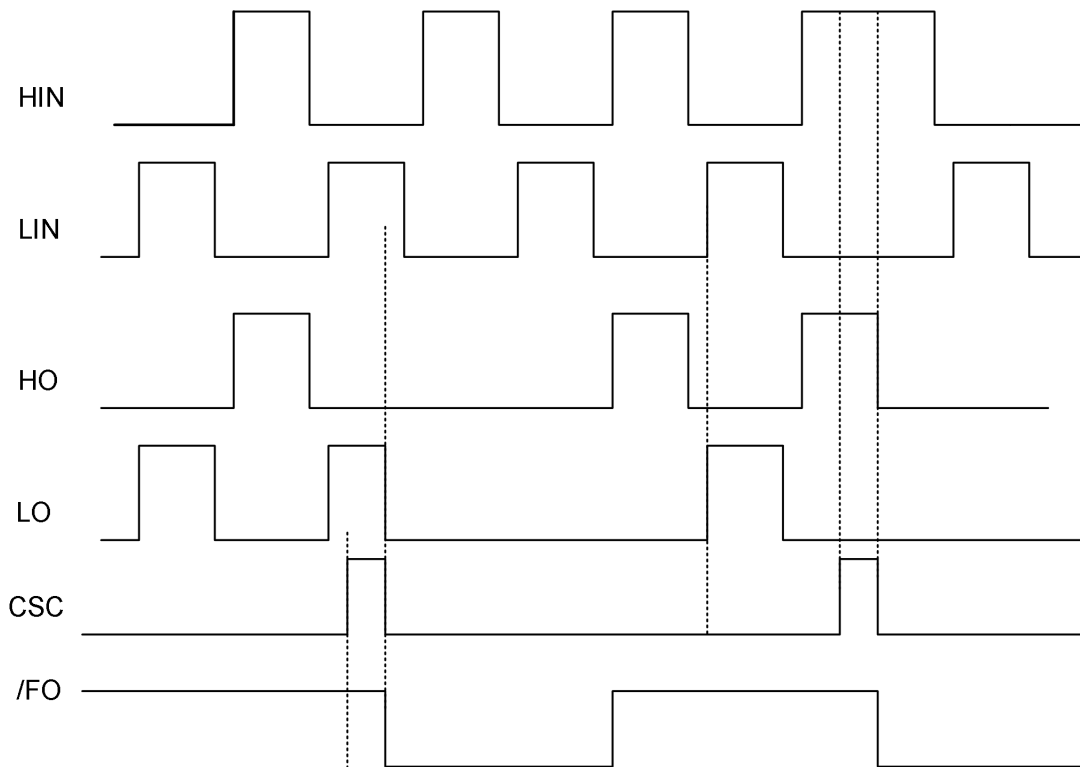

图 10.使能关断时序
Fig 10.External Shutdown Control

- HIN: 高边输入信号
High-side input signal
- LIN: 低边输入信号
Low-side input signal
- HO: 高边输出信号
High-side output signal
- LO: 低边输出信号
Low-side output signal
- CSC: 过流保护检测输入
Over current detection input
- /SDx: 使能关断输入信号
External shutdown signal



典型应用电路/Typical Application Circuit

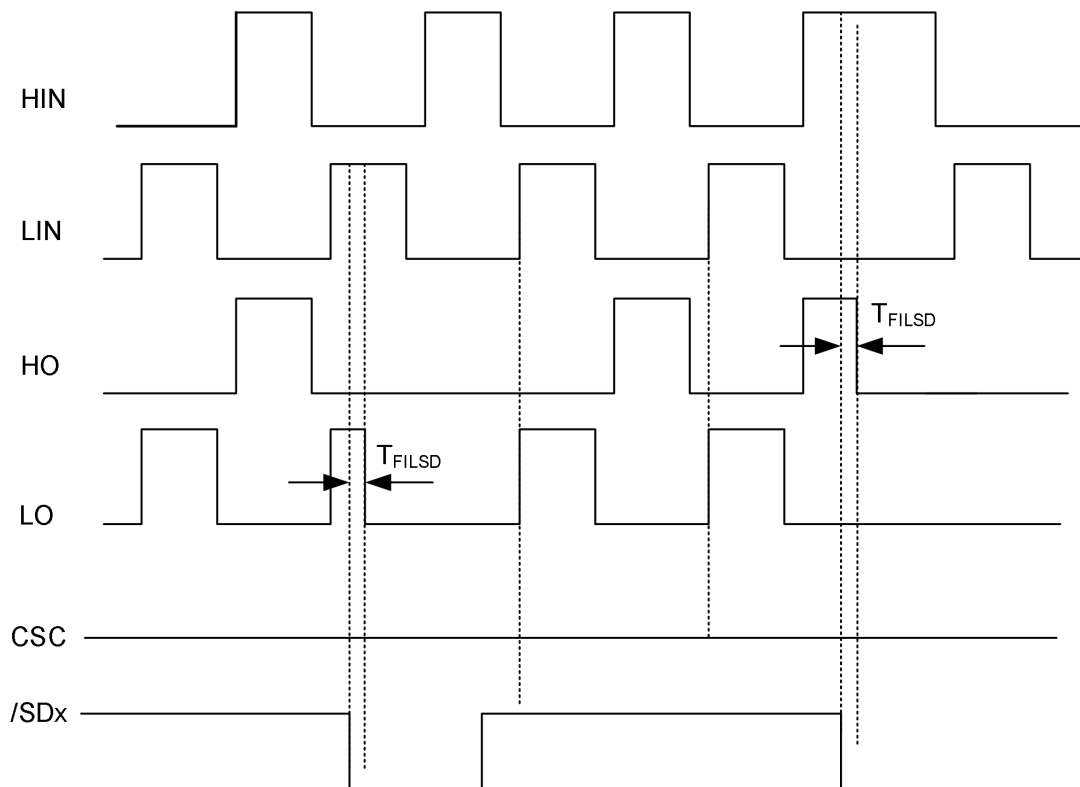
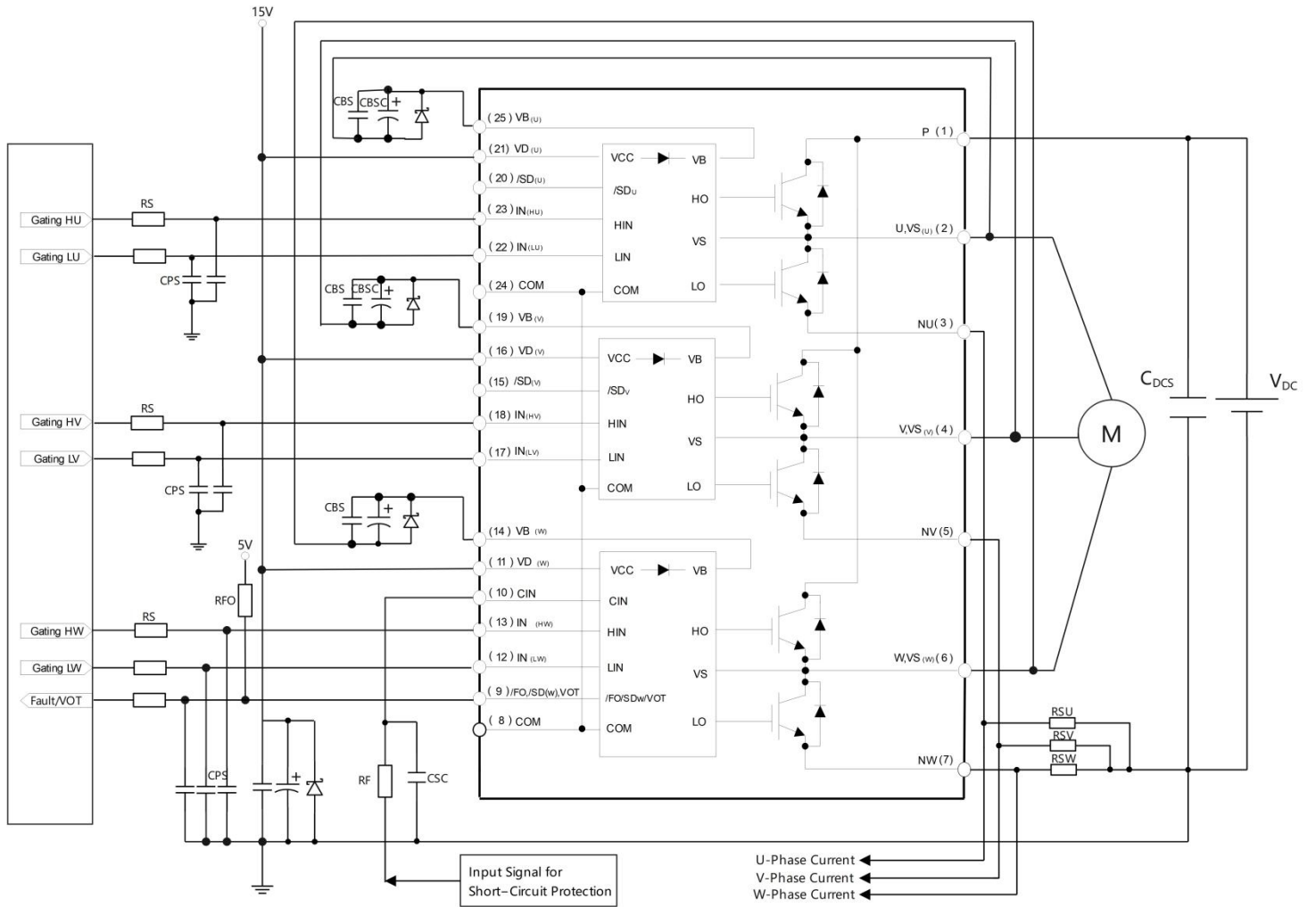

封装轮廓详图/Detailed Package Outline Drawings

封装/Package: DIP25-B-3215

(单位/Unit: mm)



图 11. 封装轮廓详图

Fig 11. Detailed Package Outline Drawings

包装/Packing

包装 package	pcs/料管 pcs/tube	料管/内盒 tube/ inner box	内盒/箱 inner box/ carton	pcs/箱 pcs/carton
料管/tube	14	6	5	420

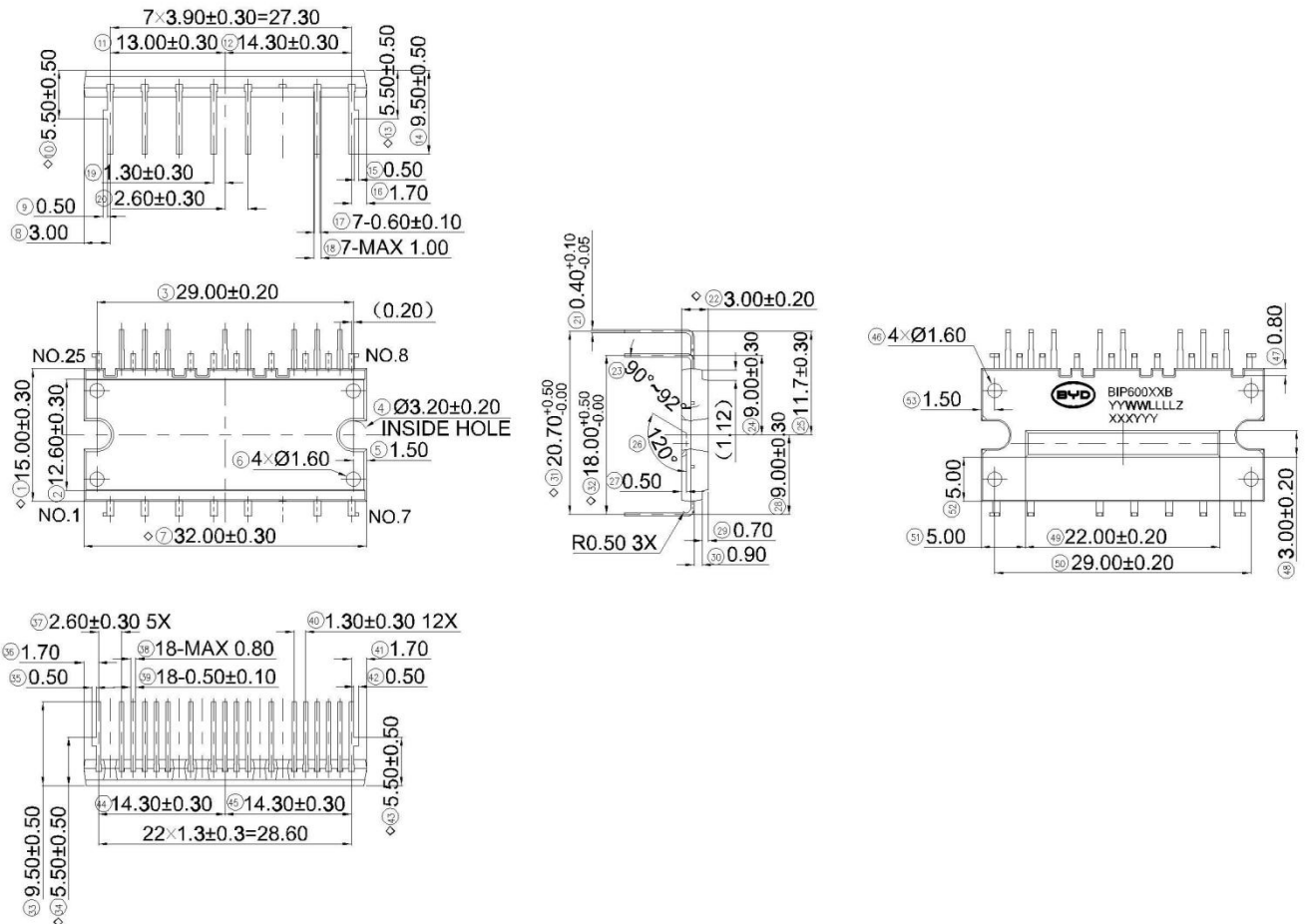
产品使用须知/RESTRICTIONS ON PRODUCT USE

- 本资料内容随产品的改进，可能会有未经预告之修改，比亚迪半导体拥有优先修改权。
- 尽管本公司一向致力于提高产品质量和可靠性，但是半导体产品有可能按某种概率发生故障或错误工作，为防止因故障或错误工作而产生人身事故，火灾事故，社会性损害等，请充分留意冗余设计、火灾蔓延对策设计、防止错误动作设计等安全设计。
- 本文所列比亚迪产品仅可应用于计算机、个人设备、办公设备、测量设备、工业机器人臂、家用电器等通用电气设备中，不可用于对精度、可靠性要求极高的设备中，也不可应用于会造成人身伤亡的设备中，不可用设备包括但不限于原子能控制器、航空航天设备、医疗设备与其他安环设备，对产品不恰当的使用将由使用者承担可能存在的风险。

- The information contained herein is subject to change without notice.
- BYD Semiconductor Co., Ltd. exerts the greatest possible effort to ensure high quality and reliability. Nevertheless, semiconductor devices in general can malfunction or fail due to their inherent electrical sensitivity and vulnerability to physical stress. It is the responsibility of the buyer, when utilizing BYD products, to comply with the standards of safety in making a safe design for the entire system, including redundancy, fire-prevention measures, and malfunction prevention, to prevent any accidents, fires, or community damage that may ensue. In developing your designs, please ensure that BYD products are used within specified operating ranges as set forth in the most recent BYD products specifications.
- The BYD products listed in this document are intended for usage in general electronics applications (computer, personal equipment, office equipment, measuring equipment, industrial robotics, domestic appliances, etc.). These BYD products are neither intended nor warranted for usage in equipment that requires extraordinarily high quality and/or reliability or a malfunction or failure of which may cause loss of human life or bodily injury ("Unintended Usage"). Unintended Usage include atomic energy control instruments, airplane or spaceship instruments, transportation instruments, traffic signal instruments, combustion control instruments, medical instruments, all types of safety devices, etc.. Unintended Usage of BYD products listed in this document shall be made at the customer's own risk.